



MIXING UNIT

Art.3895G

Description

Mixing unit for radiant heating and/or colling systems.

Function

The mixing unit can be used in radiant systems when the thermal generator available is a high temperature one. High temperature water is mixed with low temperature water supplied by the heating circuits. The temperature value of the thermal energy carrier fluid is kept constant by means of a thermostatically controlled kit (Art. 4500376) or temperature control kit (Art. 4500377).

Moreover, the mixing unit can be equipped with a module with shut-off valves (Art. 4500082) including fittings for the kit with the high temperature circuit linear manifolds (Art. 4500378).

The mixing unit can also be installed within a steel enclosure painted in white RAL9010 for indoor applications and complete of galvanised steel base and locking kit (Art. 1810132).

The Art. 3895G is supplied with high efficiency pump, in compliance to European Directive 2009/125/EC (ErP).



European Directive 2009/125/EC (ErP Directive)

This directive establishes a framework for the setting of ecodesign requirements for energy-related products.

More specifically, from January 1st, all pumps manufacturers are not allowed to sell in the European market pumps with a EEI index lower than 0.27. Standard 3-speed pumps can not be used anymore.

TECHNICAL FEATURES

Maximum inlet water temperature:	110°C
Minimum inlet water temperature:	7°C
Maximum working pressure:	10 bar
Inlet thread:	1" M
Brass:	CW 617N
O-Rings:	EPDM 70 SH
Safety thermostat:	preset 55°C

PUMP

WiiO:	PARA 25/7 (*)
Connections	1"1/2
Distance between axes	130 mm

(*) 3 speed pump available for non-EU contries

BYPASS and Cut-off kit art.3890BV



If the mixing group art. 3895G is NOT connected to a distribution manifold (e.g. art.5538G; 5539X) or to a hydraulic separator without pump, then the 3890BV kit is essential for correct mixing.

Without the bypass kit, with pressure differences between the delivery circuit and the return circuit of more than 0.3 bar, malfunctions and blockages of the mixing valve could occur.

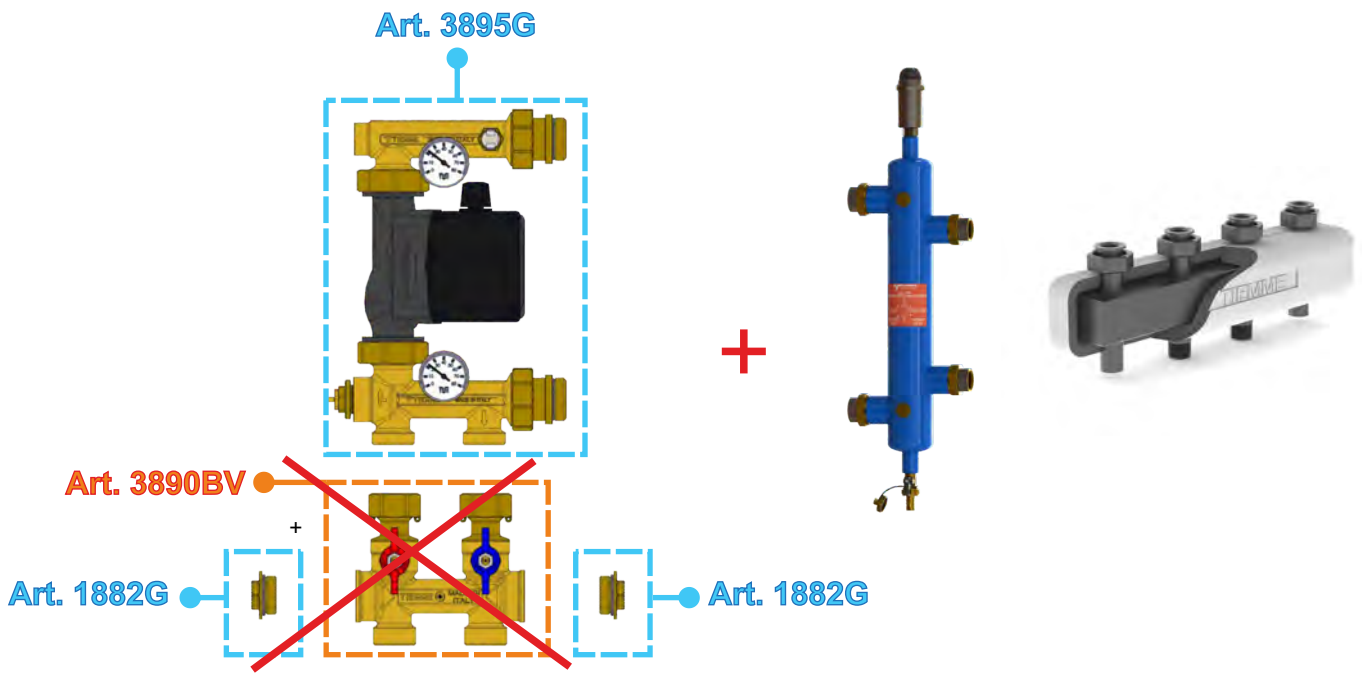
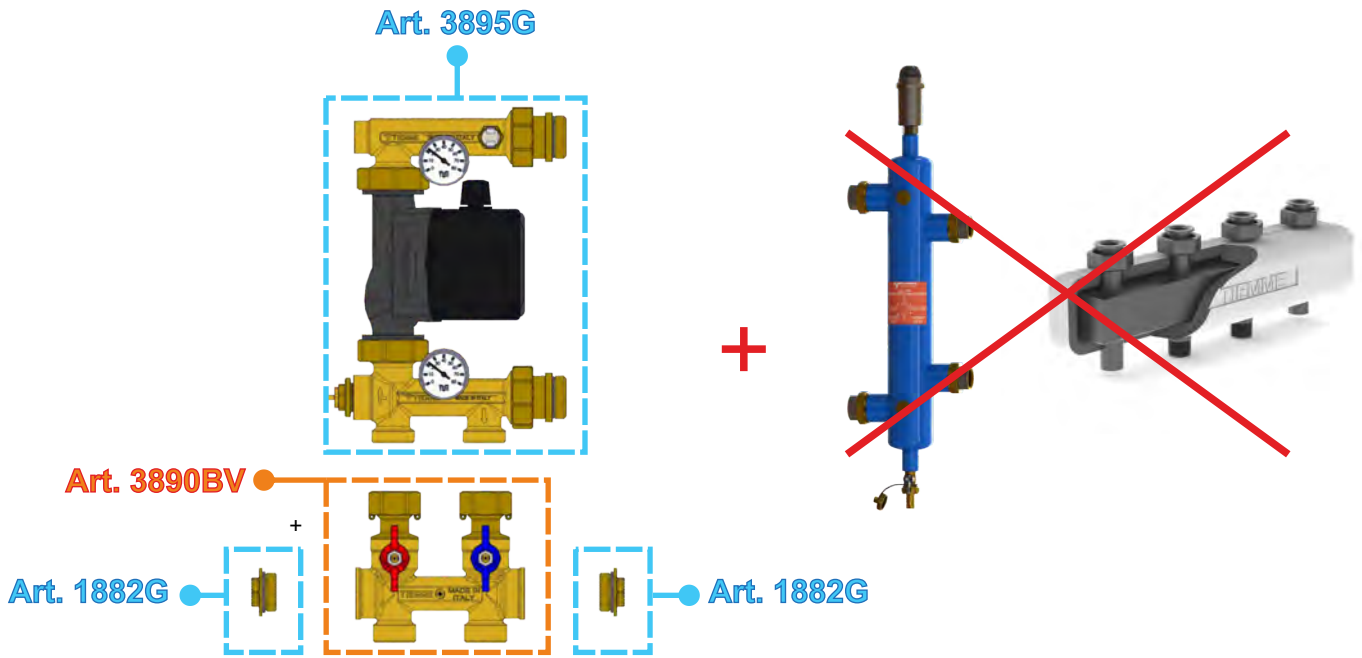

Bypass operation and regulation

The shut off and by-pass kit is provided of shut off valves for delivery and return flow and adjustable by-pass for the balancing of the circuit.

Below is shown a diagram of the pressure losses of the by-pass to different degrees of adjustment ...

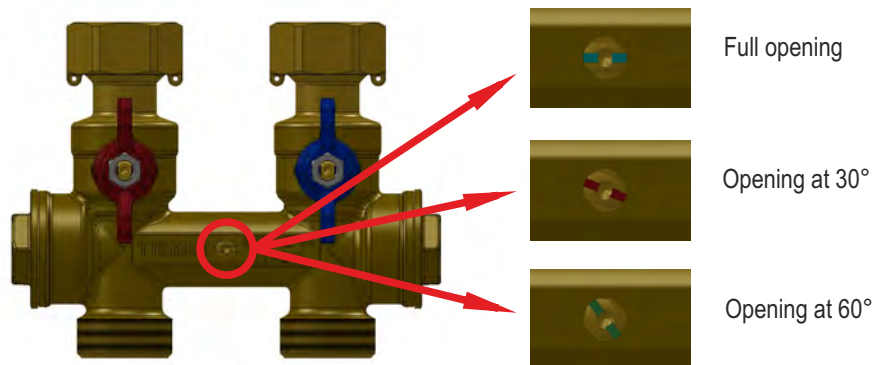

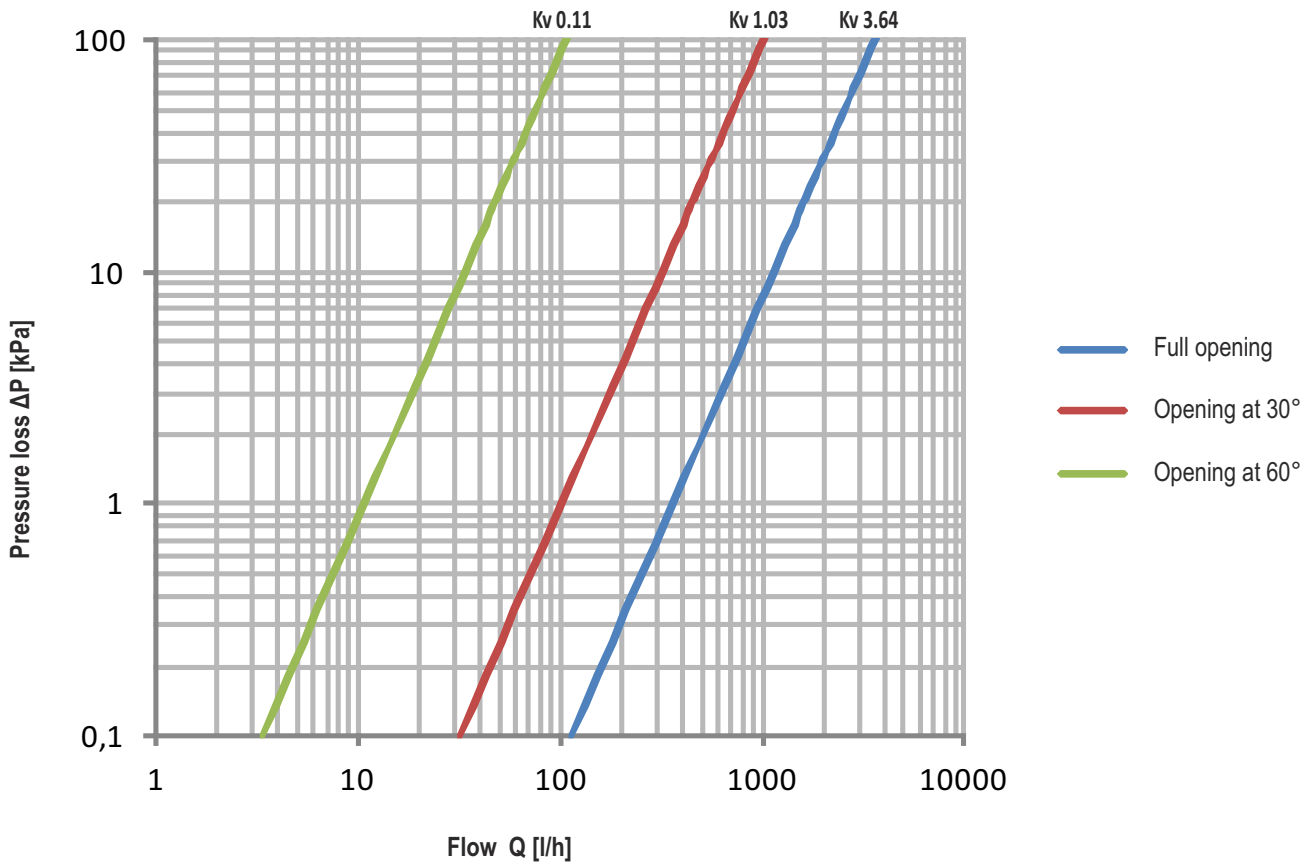

Version with fixed point control unit

The mixing group can be completed with the addition of the fixed point control kit Art. 4500376, the module with shut-off valves Art. 4500082 and the kit with the high temperature circuit linear manifolds Art. 4500378.

- A) Ball valve for high temperature water inlet (from the boiler)
- B) Ball valve for water return to the boiler
- C) 3-way mixing valve
- D) Thermostatic head with remote bulb (F) for setting the radiant panel delivery temperature (from 20 to 50°C)
- E) High-efficiency circulator pump
- F) Thermostatic head immersion bulb
- G) Safety contact thermostat with intervention threshold set at 55°C
- H) Inlet connection to the distribution manifold
- I) return from the distribution manifold
- L) Check valve
- M) By-pass with calibration valve
- N) High temperature radiator delivery manifold
- O) High temperature radiator return manifold
- P) Electrical connection kit

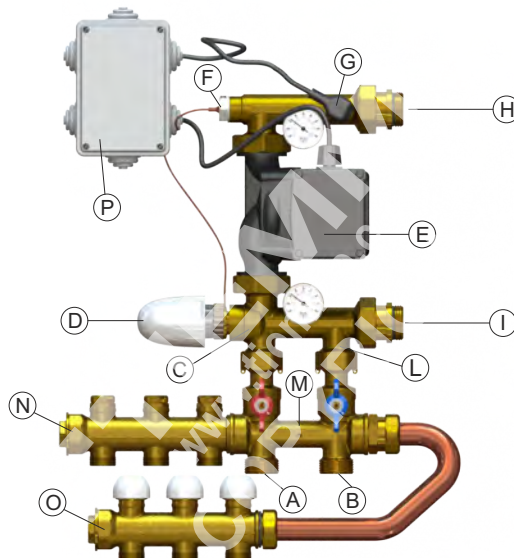



TEMPERATURE SETTING

The flow temperature is set by rotating the knob of (from 20°C to 50°C) the thermostatic head until the required value is indicated on the knob index.

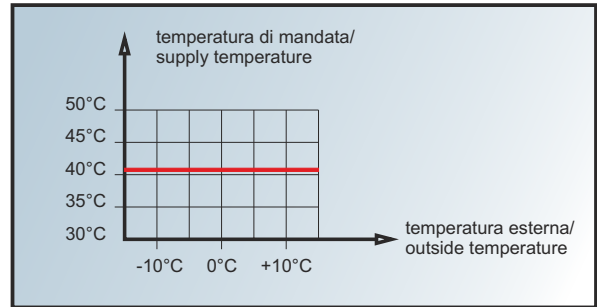

THERMOSTATIC CONTROL

When using a thermostatic control, the radiant circuit flow temperature is constant (adjustable between 20°C and 50°C), notwithstanding the outside conditions

Version with fixed point control unit

HYDRAULIC DIAGRAM

The high temperature water supplied by the boiler, through the ball valve (A) is mixed in the 3-way valve (C) with part of the water coming from the return manifold (I) of the underfloor heating system.

The temperature of the secondary circuit is kept at the set value thanks to the thermostatic head (D) on the basis of the temperature detected by the bulb temperature probe (F). By enhancing fluid mixing, the pump (E) guarantees the pressure head in the heating panel circuits. The safety thermostat (G) electrically intervenes on the pump by turning it off if the fixed value (55°C) is exceeded. The water mixed to reach the required temperature is in this way conveyed to the delivery (H) of the underfloor heating system. Part of the low temperature water returning from the panels (I) enters the valve (C) where it is mixed with water supplied by the boiler, and part returns to the boiler through the ball valve (B). The check valve (L) impedes high temperature water from entering the heating circuits. The by-pass valve (M) makes system balancing possible by constantly guaranteeing the minimum flow rate of the primary circuit. The high-temperature circuits (heated towel rails, radiators, etc.) are supplied through points (O) and (N).

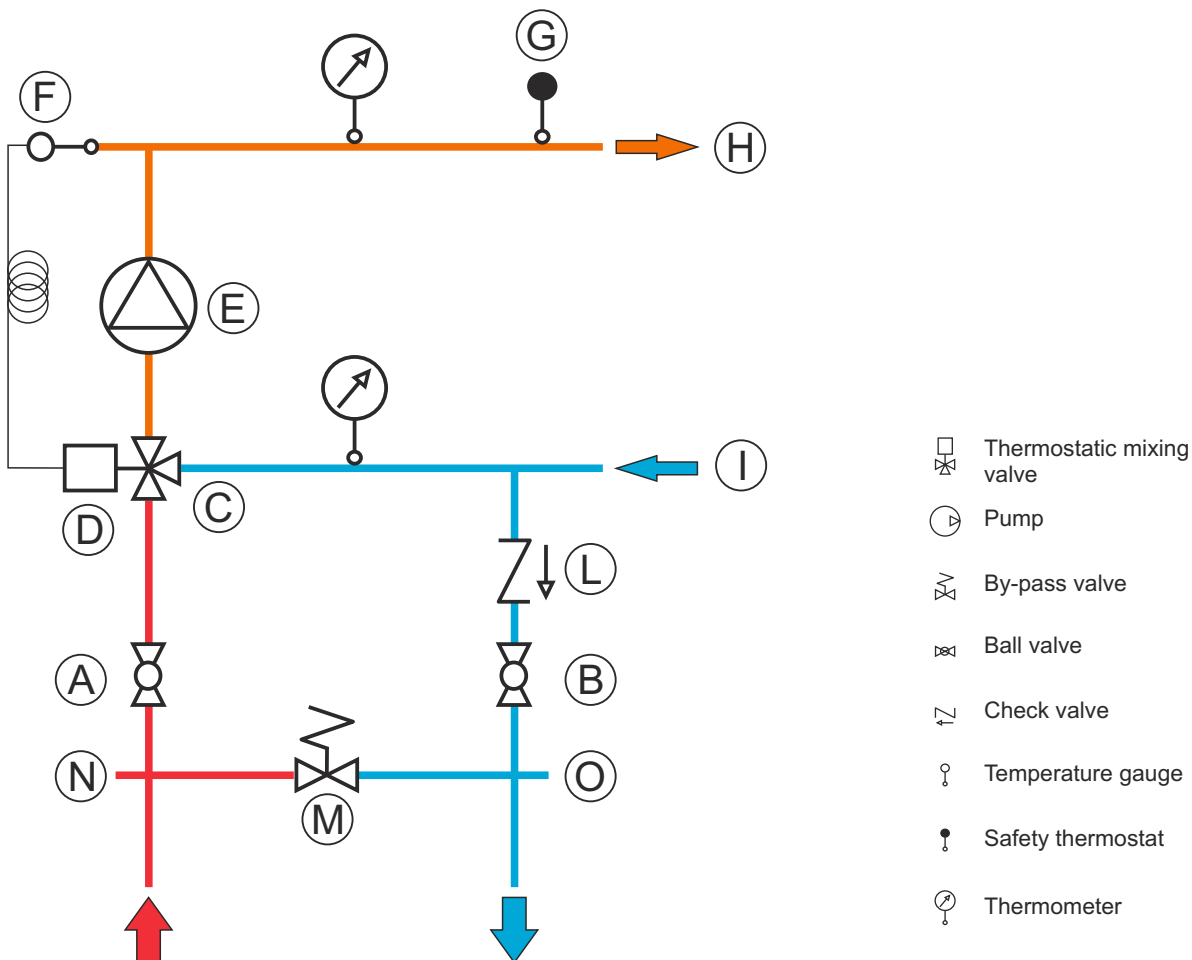



Version with climatic control unit

The mixing group can be completed with the addition of the fixed point control kit Art. 4500377, the module with shut-off valves Art. 4500082 and the kit with the high temperature circuit linear manifolds Art. 4500378.

- A) Ball valve for high temperature water inlet (from the boiler)
- B) Ball valve for water return to the boiler
- C) 3-way mixing valve
- D) Servo motor 0÷10V NC 24V
- E) High-efficiency circulator pump
- F) Probe holder with NTC temperature probe
- G) Safety contact thermostat
- H) Inlet connection to the distribution manifold
- I) return from the distribution manifold
- L) Check valve
- M) By-pass with calibration valve
- N) High temperature radiator delivery manifold
- O) High temperature radiator return manifold

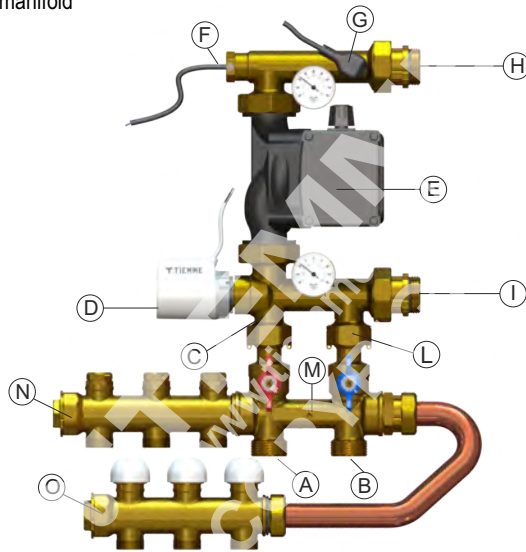

COMPONENTS FOR CLIMATIC CONTROL

MASTER stand-alone module Mod. MHC_SA

The electronic module is provided with an interface complete of alphanumeric display. The control unit makes it possible to set the heating curve both in summer and winter, the type of adjustment and accepts a remote on/off contact as well as a summer/winter switching. The device makes it possible to manage the 2 mixers with analogue actuator with 0-10 V or 4-20 mA control and a mixer with a 3 point actuator.



Outdoor temperature and humidity probe

The probe is used to detect the temperature and relative humidity parameters of the outdoor environment in order to obtain a complete climatic control.



Room temperature probe

The probe is available for flush or wall mount applications. It displays room temperature and/or makes changes to the temperature possible. The version without display is also available.

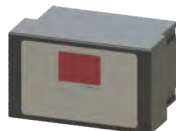



Version with climatic control unit

HYDRAULIC DIAGRAM

The high temperature water supplied by the boiler, through the ball valve (A) is mixed in the 3-way valve (C) with part of the water coming from the return manifold (I) of the underfloor heating system. The temperature of the secondary circuit is kept at the set value by means of the servo motor 0÷10V (D) on the basis of the temperature detected by the NTC temperature probe (F). By enhancing fluid mixing, the pump (E) guarantees the pressure head in the heating panel circuits. The safety thermostat (G) electrically intervenes on the pump by turning it off if the fixed value (55°C) is exceeded. The water mixed to reach the required temperature is in this way conveyed to the delivery (H) of the underfloor heating system. Part of the low temperature water returning from the panels (I) enters the valve (C) where it is mixed with water supplied by the boiler, and part returns to the boiler through the ball valve (B). The check valve (L) impedes high temperature water from entering the heating circuits. The by-pass valve (M) makes system balancing possible by constantly guaranteeing the minimum flow rate of the primary circuit. The high-temperature circuits (heated towel rails, radiators, etc.) are supplied through points (O) and (N).

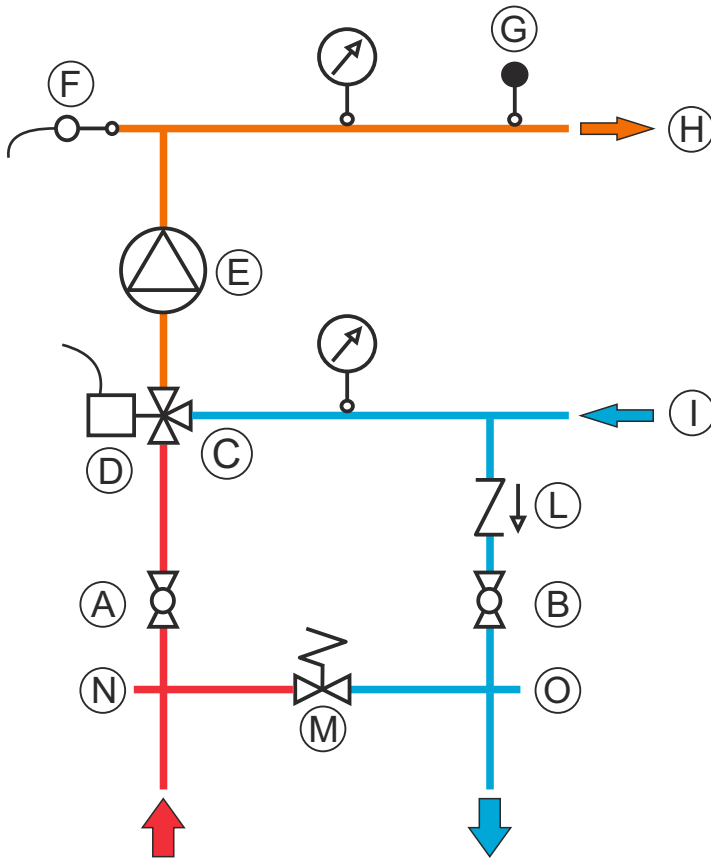

- Thermostatic mixing valve
- Pump
- By-pass valve
- Ball valve
- Check valve
- Temperature gauge
- Safety thermostat
- Thermometer



Assembly

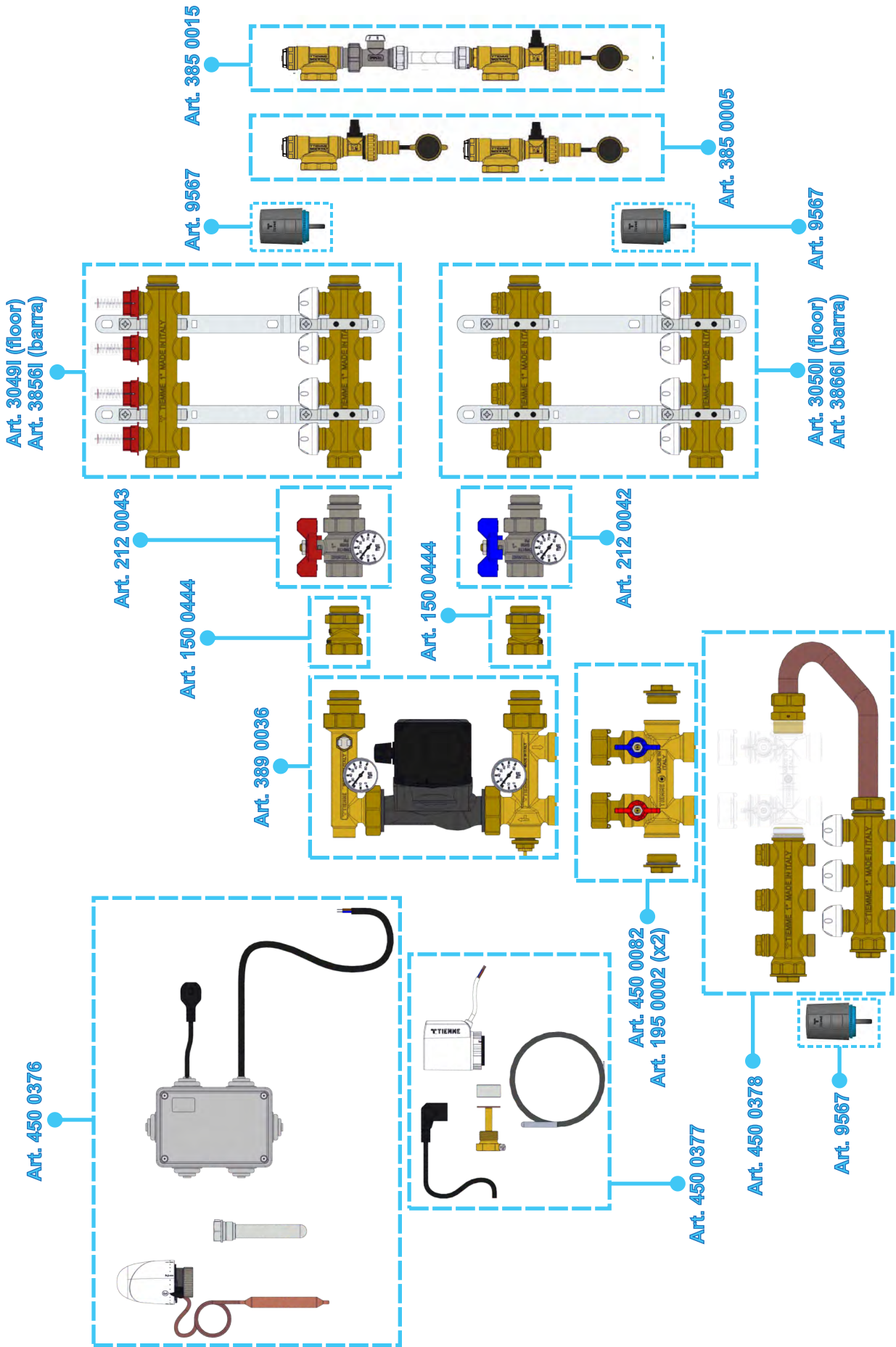



Assembly

Art. 3895KPF

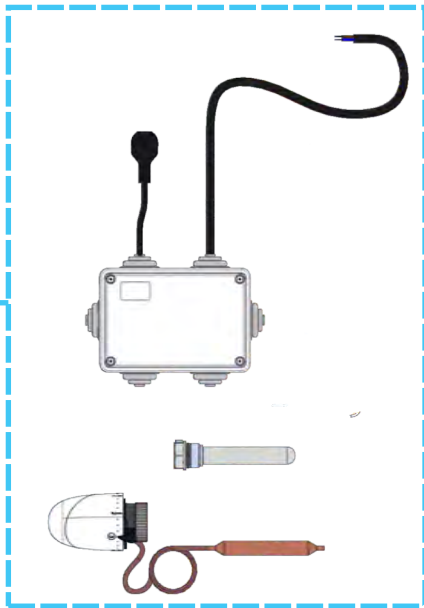

Art. 3895KCL

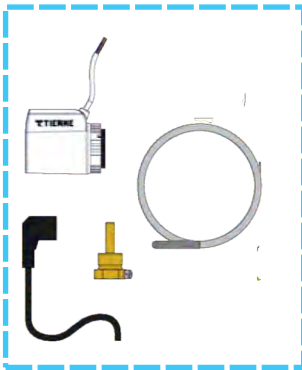

Art. 3890BV
Cod. 195 0002 (x2)

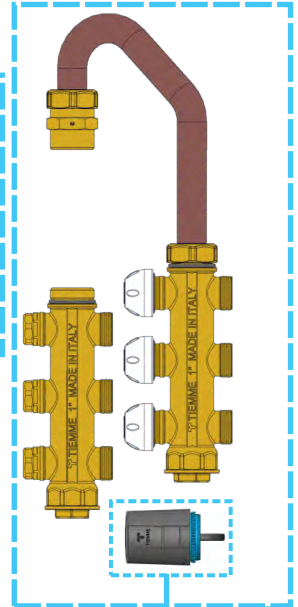

Art. 9567

Art. 3895KHT

Art. 3895G

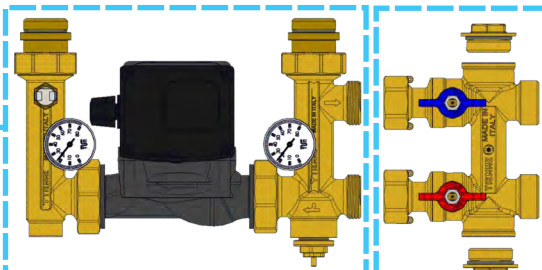

Cod. 212 0043

Art. 1513

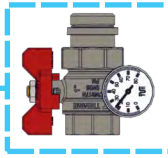

Art. 1513

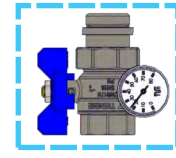

Cod. 212 0042

Art. 3856I

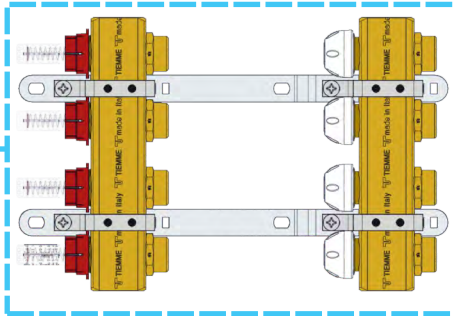

Art. 3866I

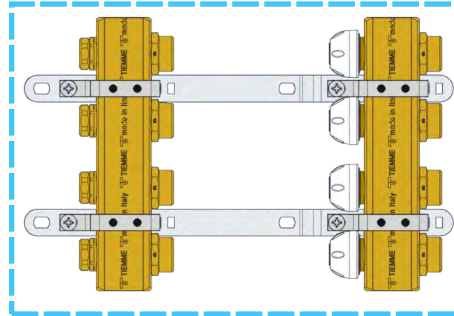

Art. 3891BY

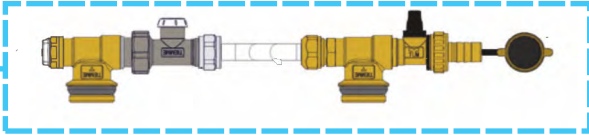

Art. 9567

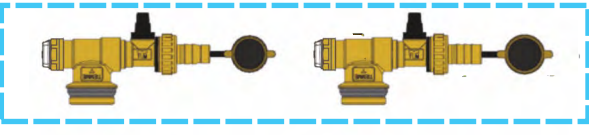

Art. 3891

Art. 9567





Dimensions

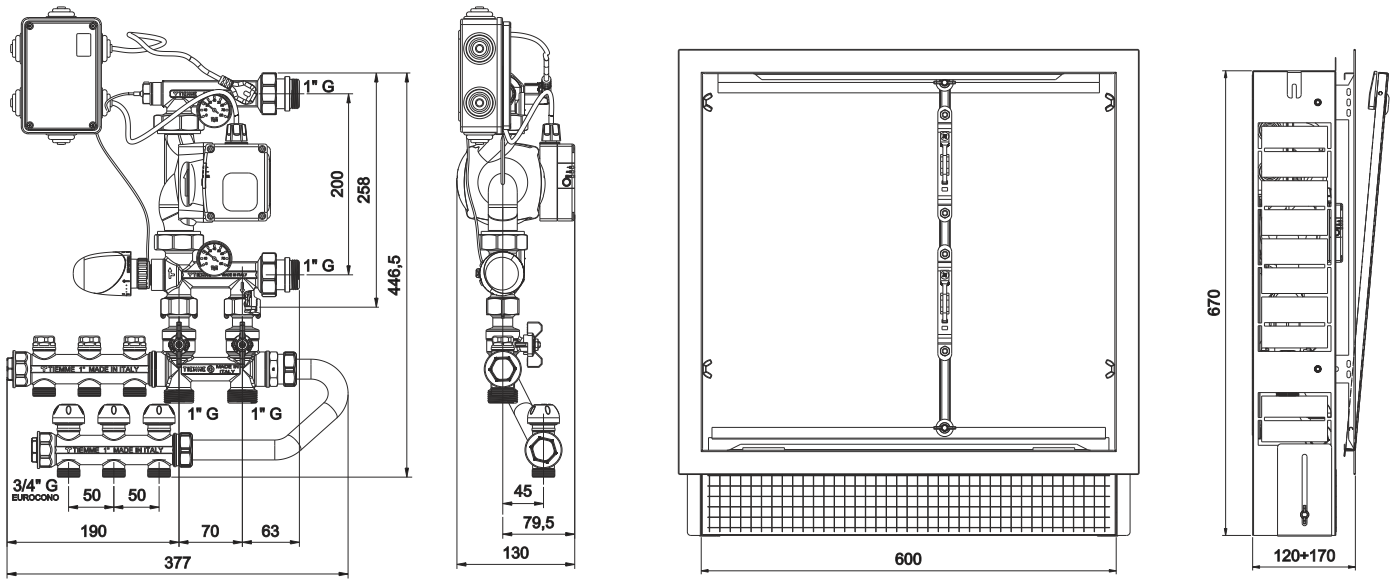

DIMENSIONS AND METAL BOX

The mixing unit is supplied without the metal box. The box, (Art. 1810132), is made of galvanized steel and can be adjusted in height (670 to 780mm) and in depth (120 to 170mm). The frame and the cover are white RAL9010 painted for indoor use. The is supplied with the brackets to fix the mixing unit.

MIXING UNIT MOUNTING BOX

The mixing unit has to be mounted on the metal box Art. 1810132 sliding rails using the two metal brackets supplied placed as shown on picture below. Is always better to fix the mixing unit in the center of the box.

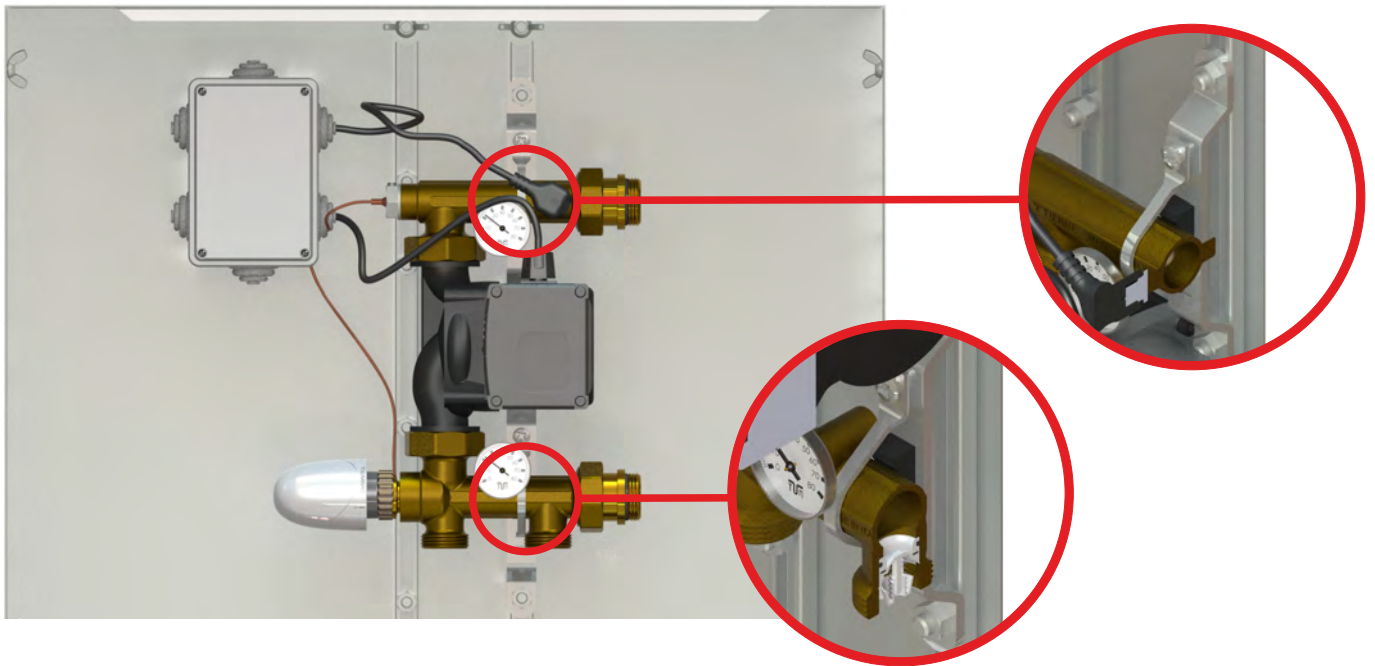



Pressure loss diagram

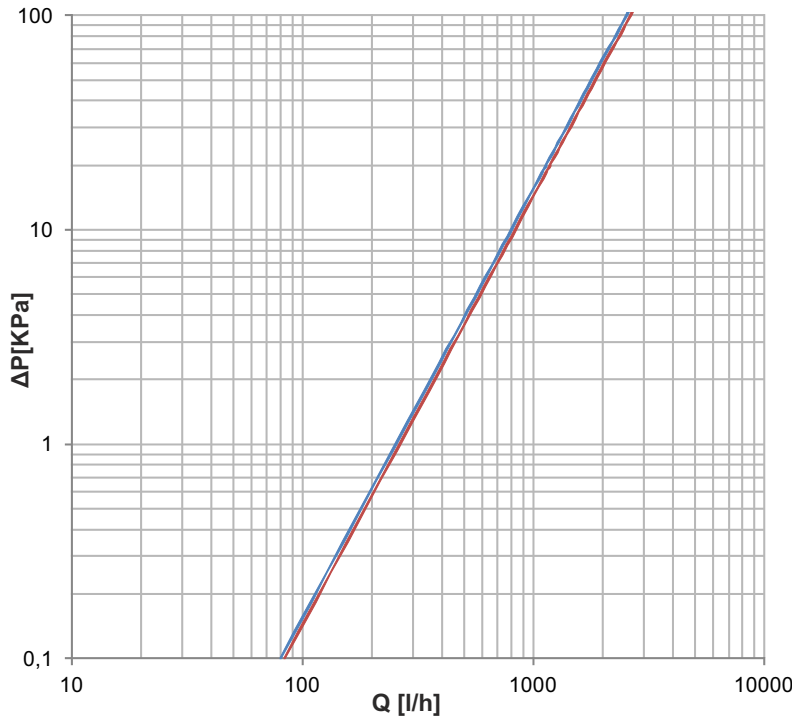

Kv 2,55 Mixing unit complete of Wilo
PARA 25/7 circulator

Kv 2,66 Mixing unit without circulator

Accessories

Art. 3895KPF



Art. 3895KCL



Art. 3895KHT



Specifications

Mixing unit composed by : CW617N brass bodies with 1" M connections to primary circuit and 1" M with tail nuts connections to secondary circuit, integrated three ways mixing valve with thermostatic screw made of CW617N and EPDM sealing, polymer check valve on primary circuit return, safety thermostat factory setted to $55^{\circ}\text{C} \pm 3^{\circ}\text{C}$, thermometers for delivery and return temperature fluid control, temperature probe housing (for secondary circuit temperature regulation) and high efficiency pump (EEI 0.23) in compliance to European Directive 2009/125/EC (ErP) with variable speed and permanent magnets, power supply 230 V - 50 Hz, power 7-48 W, protection grade IP 44.

To be used with : water or glicol solution (max 30% of glicol). Maximum working temperature from primary circuit 110°C . Minimum working temperature from primary circuit 7°C . Maximum working pressure 10bar.

TIEMME Raccorderie S.p.A.
Via Cavallera 6/A (Loc. Barco) - 25045 Castegnato (Bs) - Italy
Tel +39 030 2142211 R.A. - Fax +39 030 2142206
info@tiemme.com - www.tiemme.com