

## Centrifugal performance characteristics with axial flow pattern: RADAX® VAR

### COMPACT



In their compact casing, the RADAX® VAR impellers ensure high pressure and a large volume conveyed. The VAR's recipe for success lies in the combination of the performance characteristics of centrifugal fans with an axial flow pattern. Guiding the air in a straight line improves the efficiency and allows a significant reduction of the space required, as well as savings in terms of the ducting system.

### PRESSURE-RESISTANT



**This synergy has enormous benefits:**

- Maximum performance with low energy costs.
- Low sound levels.
- High-pressures and volumes with the smallest of dimensions.
- Can be used universally.
- Freedom of planning.
- No need for deflections and shaped pieces on-site with the related resistances.
- Low installation costs.

### UNIVERSAL



In addition to single phase types, the RADAX® VAR range offers the following:

- More Ø up to 1000 mm
- B VAR types for the smoke extraction insert pursuant to DIN 12101-3 F300 (60 min.) or F400, F600 (120 min.).
- Parallel units with large volumes and high pressures for garage ventilation (VDI 2053).
- Two-stage TwinVent® with maximum pressure values.

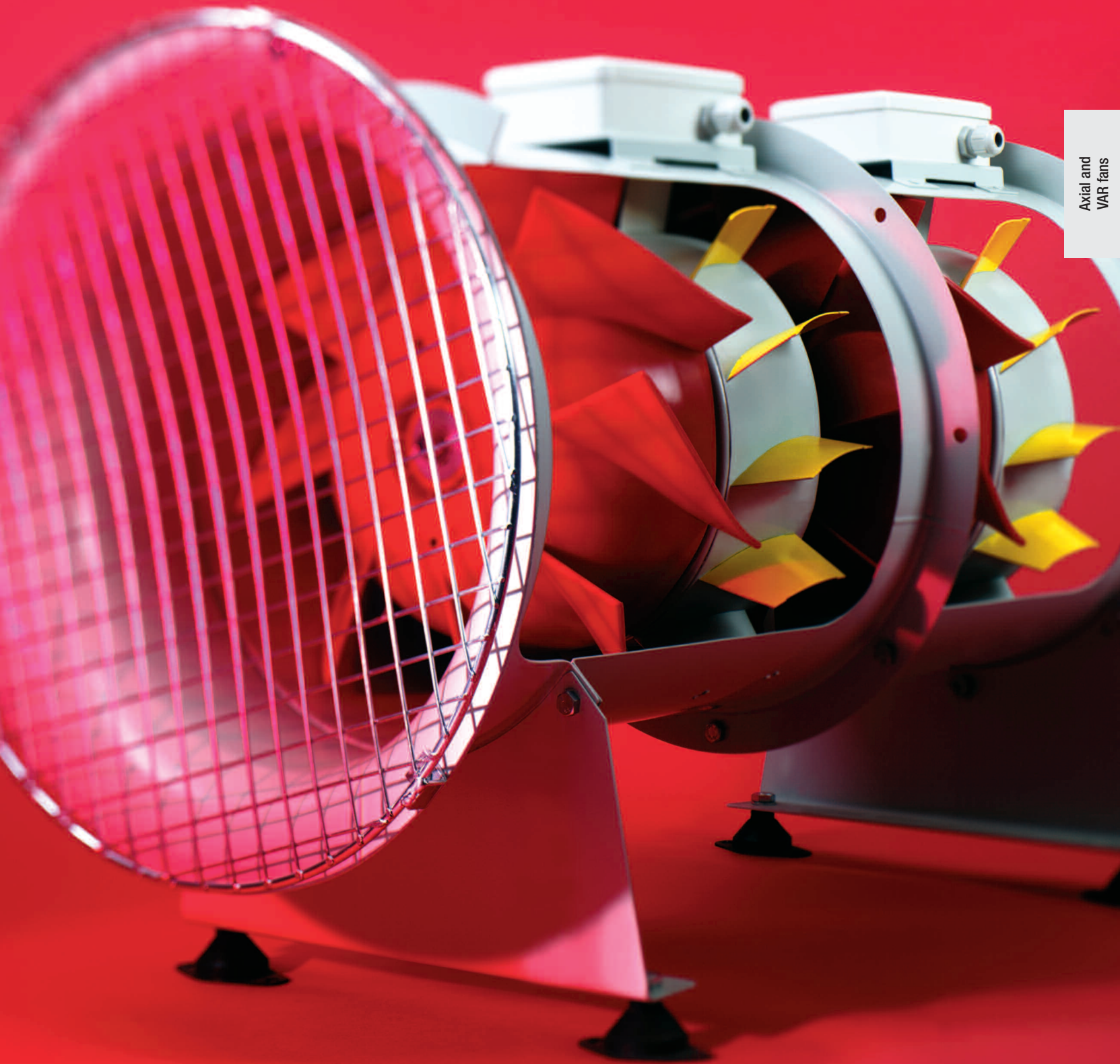

Axial and VAR fans

This information completes the "General Technical Information" section.

**Features**

RADAX® VAR is a range of high pressure in-line fans, combining the advantages of axial and centrifugal fans.

The mixed flow impeller combined with the fixed guide vanes are designed to provide high air flows and pressures very efficiently.

**Air flow**

The axial air flow pattern allows operation without loss, guide vanes improve and straighten the air and increase the efficiency of the fan. The VAR in-line installation eliminates the need for bulky bends, transformation pieces etc. including their resistances. This saves installation and energy costs.

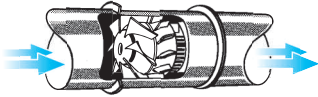

**Casing**

Casing flanges on both sides to DIN 24155, Pt.3 with guide vanes and motor support made from galvanised steel. Models with R.P.M. = 2800 of size 400, 450, 500 as well as all models of size 630 welded casing, hot-dip galvanised. Terminal box to IP 55 fixed to the outer casing.

**Impeller**

Mixed flow impeller with 8 spacious curved blades. Up to size 355 made from polymer. Models with R.P.M. = 2800 of size 355 as well as all models of size 400 to 630 made from hot-dip galvanised steel. Aluminium is available (additional charge) on demand.

VAR fans offer high efficiency, low operation noise, high corrosion resistance and low vibration operation through dynamic balance to DIN ISO 1940 Pt. 1 – quality grade 6.3.

**Air flow temperature**

The standard models are suitable in the range from -30 °C to at least +40 °C. See also information on product pages. Higher temperature models are available on request.

**Explosion protection**

The ex-proof models conform to cluster II, category 2G for operation in zone 1 or 2. According to Directive 2014/34/EU (ATEX), larger air gaps are specified which lead to a power reduction of up to 10%.

**Air flow direction**

The air flow of the fan cannot be reversed, however the fan is suitable for installation in any position. The correct direction of rotation and air flow are marked on the fan.

**Installation position, mounting, condensation openings**

To achieve the performance figures shown, a straight duct of 2 times the diameter in length downstream of the fan is required (and installed in ducting ideally the same upstream) (Figure 1).

RADAX® VAR can be installed in any position. Where motor condensate drainage is used, ensure the drain holes face downwards.

When installing the fan for vertical airflow as well as in an outside position or in a permanently humid or wet atmosphere, this must be specified at time of ordering.

On site assembly and mounting must be carried in such a way that the vertically fitted fan is distortion-free and safe.

**Positioning**

To avoid transmission of vibration between fan and building the use of anti vibration mounts is recommended (accessory SDD, SDZ). Larger motors may protrude to the rear and cause uneven distribution due to their high weight. An extension duct VR (accessories) is provided to determine the centre of gravity!

**Installation examples**

**Horizontal**

**Figure 2**

Free intake, ducted on exhaust. Mounted on ceiling, wall or floor.

**Figure 3**

Free intake with attenuator, ducted on exhaust. To reduce inlet and exhaust noise levels, attenuators can be fitted to both ends of the fan.

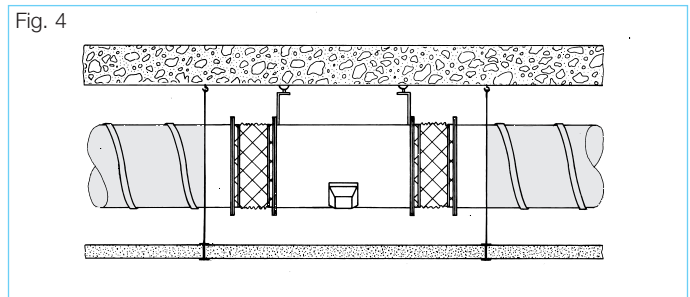
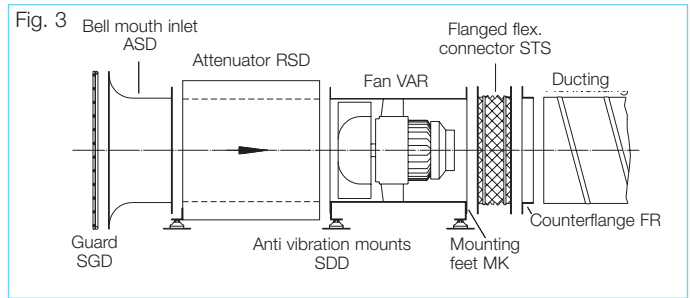
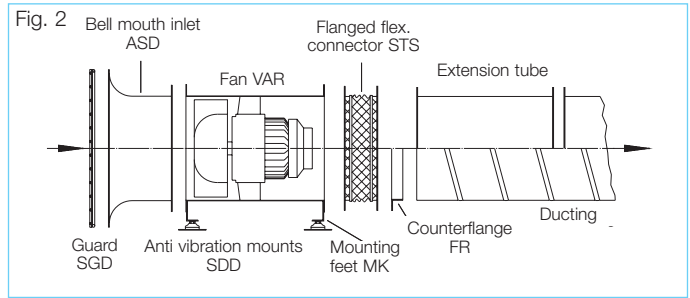
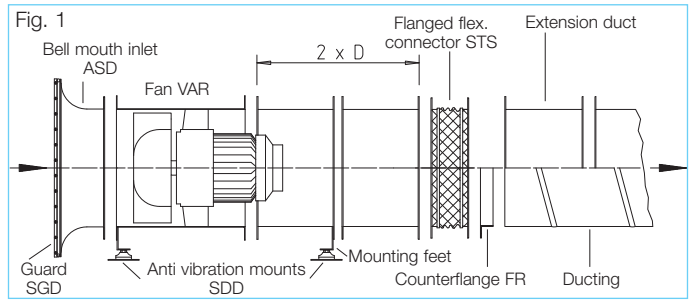

**Figure 4**

**Ceiling suspension**

Figure 4 shows the typical installation for ventilation. The installation of VAR systems is possible without any additional expenses through direct suspension on ceilings or walls. The casing is designed for straight in-line installation using the flanged ends (to DIN 24155 Pt. 3).

**Vertical**

**Figure 5**

In-line wall mounted installation with attenuator on intake. The accessories should be fixed separately to ensure that the fan may be easily removed for maintenance.

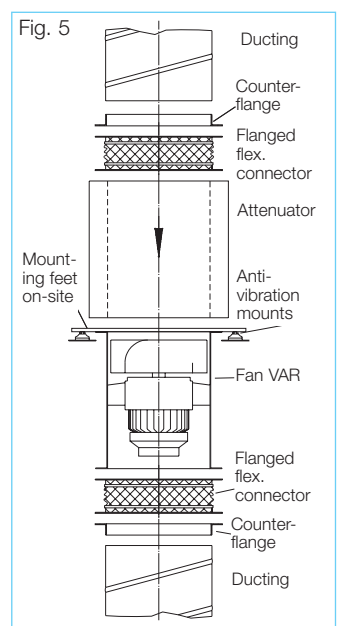

Information	Page
Information for planning, Acoustics, explosion prot.	10 on
General technical information, speed control	15 on

The following table facilitates the selection of RADAX® VAR high pressure fans by combining the parameters of static pressure  $\Delta p_{sta}$ , air flow volume  $V$ , speed  $\text{min}^{-1}$ , sound pressure level  $\text{dB(A)}$  and impeller diameter  $\text{DN}$  mm.

Sizes from  $\varnothing 710$  mm as well as twin and parallel VAR units are shown in a separate catalogue.

Diameter	R.P.M.	Sound pressure level - intake	Air flow volume $V$ m <sup>3</sup> /h against static pressure = $N / m^2$ = free available pressure												
mm	min <sup>-1</sup>	$L_{PA}$ dB(A)	$(\Delta p_{sta})$ in Pa												
		at 4 m	0	50	100	150	200	300	400	500	600	700	800	900	1000
225	2800	61	1770	1700	1600	1510	1400								
225	1450	46	900	730											
250	2800	64	2540	2450	2350	2250	2150	1910							
250	1450	49	1250	1050											
280	2800	68	3320	3220	3110	3010	2900	2670	2360						
280	1450	52	1630	1400	1000										
315	2800	71	4670	4550	4430	4310	4200	3930	3650	3280					
315	1450	56	2510	2300	2060	1730									
355	2800	75	7220	7080	6980	6850	6700	6450	6150	5850	5500	5050			
355	1450	60	3540	3300	3050	2750	2200								
400	2800	78	10150	10000	9850	9700	9600	9300	9000	8700	8350	7950	7500	7100	6400
400	1450	63	5260	4950	4650	4310	3930								
400	930	52	3500	3060	2290										
450	2800	83	14200	14100	13900	13750	13600	13300	12900	12500	12200	11800	11400	10800	10350
450	1450	67	7280	6950	6650	6300	5900	4800							
450	930	56	4990	4520	3870										

Diameter	R.P.M.	Sound pressure level - intake	Air flow volume $V$ m <sup>3</sup> /h against static pressure = $N / m^2$ = free available pressure												
mm	min <sup>-1</sup>	$L_{PA}$ dB(A)	$(\Delta p_{sta})$ in Pa												
		at 4 m	0	150	300	450	600	750	900	1050	1200	1550	1800		
500	2800	86	22310	21800	21400	20800	20300	19750	19200	18600	17900	16000	13500		
500	1450	70	9700	8640	7300										
500	930	59	6860	5150											
560	1450	73	13550	12500	11300	9850									
560	930	63	9850	8110											
560	725	56	7510												
630	1450	77	21460	20410	19110	17610	15760								
630	930	67	14040	12190	8740										
630	725	60	10690	7810											
<b>The following sizes are shown in a separate catalogue.</b>															
710	1480	81	31350	30210	28920	27370	25680	23710	20790						
710	950	70	20110	18120	15390										
710	725	64	15330	12380											
800	1480	85	44870	43580	42210	40610	38810	36910	34780	32130	26670				
800	950	74	28770	26640	23850	19970									
800	725	67	21940	18810											
900	1480	88	63890	62450	60940	59300	57440	55410	53310	50990	48420	39610			
900	950	78	40990	38650	35710	32250	26830								
900	725	71	31260	27910	23160										
1000	1480	92	87640	86050	84410	82590	80770	78650	76400	74110	71650	66090	57450		
1000	950	81	56220	53690	50670	47080	42960	36050							
1000	725	74	42880	39330	34590	25090									

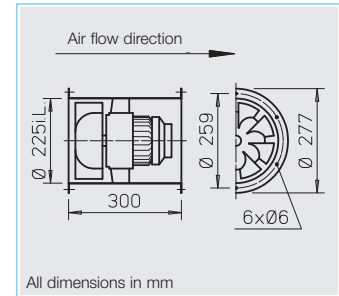

**■ Specification**

**□ Casing**

Manufactured in galvanised sheet steel with flanges on both sides to DIN 24155, Pt. 3, with fixed guide vanes and motor support.

**□ Impeller**

Optimised for high pressure and performance. Specially developed mixed-flow curved impeller manufactured from impact resistant polymers.

**□ Motor**

Direct driven, maintenance free flange motor, totally enclosed with an aluminium casing and cooling fins, protected to IP 54. Sealed for life ball bearings with tropicalized protection of windings and radio suppression. Optional drainage holes made to order (please state installation position).

**□ Speed control**

For all speed controllable models the current is given in the “speed controlled” column of the table below which must be used when selecting a controller (see controller column). The air flow volumes can be seen from the characteristic curves. If the fan is to be controlled by a frequency inverter without a sine filter, this must be stated when ordering. This requires a change of fan design and potential additional costs. Explosion proof fans are not controllable.

**□ Electrical connection**

Terminal box fitted externally on the casing as standard (IP 55).

**□ Installation**

Installation in any position. Ensure that motor drainage holes (where used) face downwards.

**□ Motor protection**

All models (3~ except ex proof) have thermal contacts as standard which must be connected to a full motor protection unit (see table below). With the 1 ph. ex-proof models thermal contacts are wired in series with the winding which automatically resets after cooling. Models without thermal contacts must be protected by a conventional circuit breaker.

**□ Sound levels**

Data shown within the performance curves refer to sound power levels. For determination of the lower sound pressure levels refer to diagram on “Technical information” page. Sound immission and acoustic information on page 10 on.

**■ Information Page**

Technical description	208
Selection chart	209
Design of systems	10 on

**Made to order designs**

Alternative voltages, frequencies, protection classes, acid protection, high temperatures etc. are available on request.

For safety and correct use note the technical information on page 15 on.

Type	Ref. no.	R.P.M.	Air flow volume (FID)	Motor power*	Voltage	Current*		Wiring diagram	Maximum air flow temp.		Nominal weight (net)	5 step transformer controller Pole switch		Full motor protection starter using the motor thermal contacts		Anti vibration mounts	
						standard supply	speed controlled		standard supply	speed controlled		Type	Ref. no.	Type	Ref. no.	comp	susp
			min <sup>-1</sup>	V m <sup>3</sup> /h	kW	V	A	A	No.	+°C	+°C	kg			Type	Type	
<b>1 Phase motor, 1 ph. / 50 Hz, protection to IP 54</b>																	
VARW 225/4	6660	1450	900	0.10	230	0.50	0.55	966	60	40	10.5	MWS 1 <sup>1)</sup>	1947	MW	1579	SDD 1	SDZ 1
VARW 225/2	6661	2770	1778	0.35	230	1.90	2.50	966	60	40	10.5	MWS 3 <sup>1)</sup>	1948	MW	1579	SDD 1	SDZ 1
<b>3 Phase motor, 50 Hz, protection to IP 54</b>																	
VARD 225/4	6662	1420	880	0.10	400Y	0.20	0.20	469	60	40	10.5	RDS 1 <sup>1) 4)</sup>	1314	MD	5849	SDD 1	SDZ 1
VARD 225/2	6663	2720	1750	0.28	400Y	0.60	0.60	469	60	40	10.5	RDS 1 <sup>1) 4)</sup>	1314	MD	5849	SDD 1	SDZ 1
													Pole switching, 2 speed motor (Dahlander windings Y/YY), 3 ph. / 50 Hz, protection to IP 54				
VARD 225/4/2	6771	1460/2800	880/1800	0.06/0.30	400	0.22/0.57	—	472	60	—	10.5	PDA 12 <sup>3)</sup>	5081	M 3 <sup>2)</sup>	1293	SDD 1	SDZ 1
<b>Explosion proof, E Ex de II B, 1 ph. / 50 Hz, temperature class T1-T3, protection to IP 55</b>																	
VARW 225/4 Ex	6733	1400	950	0.06	230	0.70	—	757	40	—	12.0	not permitted	—	—	SDD 1	SDZ 1	
VARW 225/2 Ex	6734	2650	1780	0.18	230	1.23	—	757	40	—	12.5	not permitted	—	—	SDD 1	SDZ 1	
<b>Explosion proof, E Exe II, 3 ph. / 50 Hz, temperature class T1-T3, protected to IP 54</b>																	
VARD 225/4 Ex	6664	1400	940	0.12	400	0.41	—	470	40	—	12.5	not permitted	not permitted	SDD 1	SDZ 1		
VARD 225/2 Ex	6665	2850	1930	0.25	400	0.72	—	470	40	—	12.5	not permitted	not permitted	SDD 1	SDZ 1		

\* Ex models: For nominal value of motor see information on page 16 <sup>1)</sup> includes full motor protection unit <sup>2)</sup> includes operation and speed switch <sup>3)</sup> see product page for flush mounted version <sup>4)</sup> Frequency inverter with integrated Sine filter, Type FU-BS 2,5, No. 5459, see product page FU.

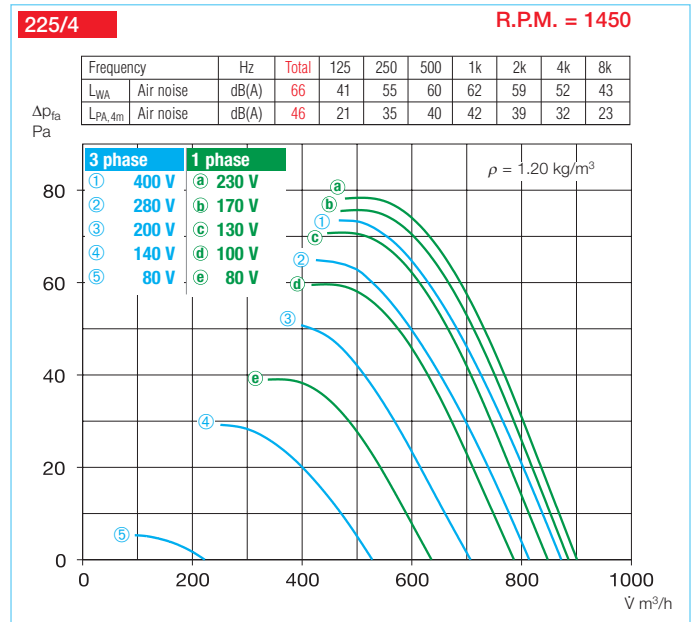
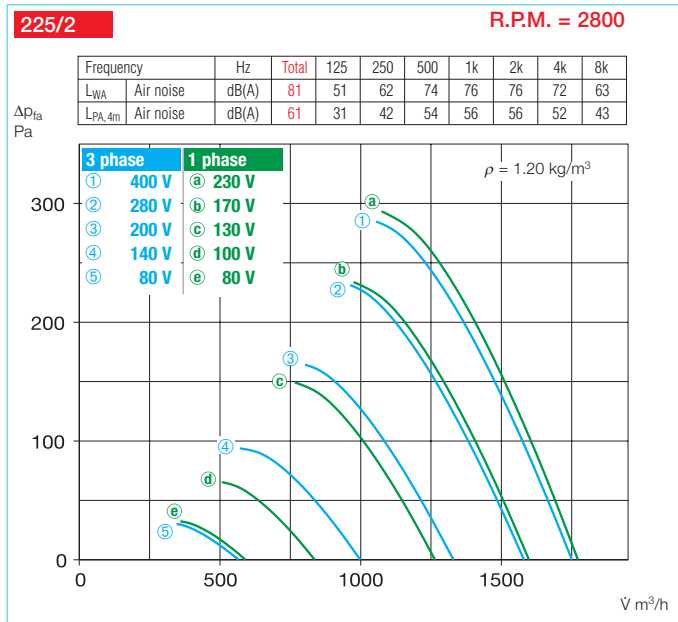

Other accessories	Page
<b>b) Accessories for ex-proof fans</b>	
Flanged flexible connector	
Type STS 225 Ex	Ref. no. 2500
Flexible sleeve	
Type FM 225 Ex	Ref. no. 1687
Attenuators	421 on
Shutters and grilles	487 on
Speed controllers and switches	525 on

Accessories Specification see page 231 on

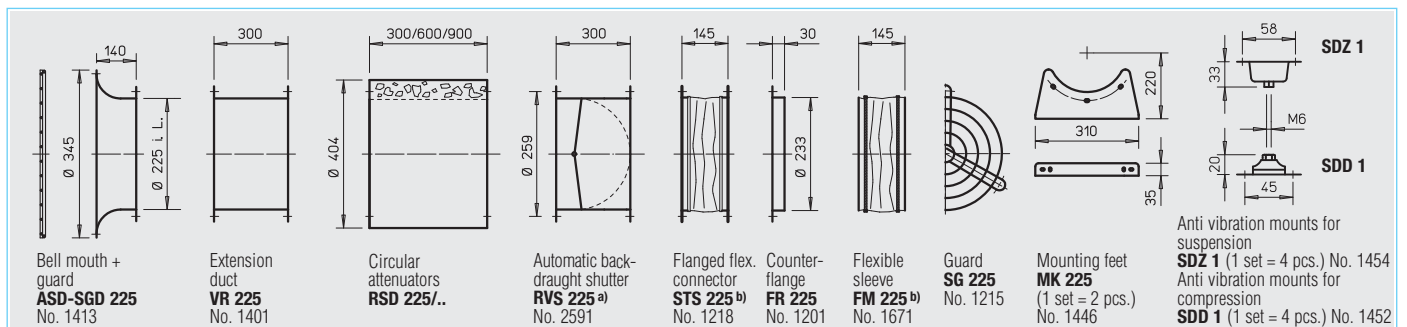

<sup>a)</sup> For motorised shutters see accessory pages

<sup>b)</sup> Types for explosion proof fans see above

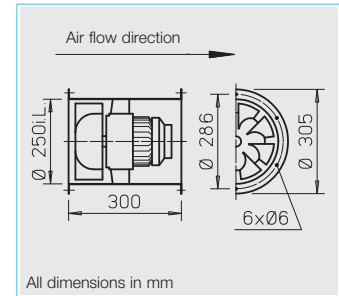

■ **Specification**

□ **Casing**

Manufactured in galvanised sheet steel with flanges on both sides to DIN 24155, Pt. 3, with fixed guide vanes and motor support.

□ **Impeller**

Optimised for high pressure and performance. Specially developed mixed-flow curved impeller manufactured from impact resistant polymers.

□ **Motor**

Direct driven, maintenance free flange motor, totally enclosed with an aluminium casing and cooling fins, protected to IP 54. Sealed for life ball bearings with tropicalized protection of windings and radio suppression. Optional drainage holes made to order (please state installation position).

□ **Speed control**

For all speed controllable models the current is given in the “speed controlled” column of the table below which must be used when selecting a controller (see controller column). The air flow volumes can be seen from the characteristic curves. If the fan is to be controlled by a frequency inverter without a sine filter, this must be stated when ordering. This requires a change of fan design and potential additional costs. Explosion proof fans are not controllable.

□ **Electrical connection**

Terminal box fitted externally on the casing as standard (IP 55).

□ **Installation**

Installation in any position. Ensure that motor drainage holes (where used) face downwards.

□ **Motor protection**

All models (3~ except ex proof) have thermal contacts as standard which must be connected to a full motor protection unit (see table below). With the 1 ph. ex-proof models thermal contacts are wired in series with the winding which automatically resets after cooling. Models without thermal contacts must be protected by a conventional circuit breaker.

□ **Sound levels**

Data shown within the performance curves refer to sound power levels. For determination of the lower sound pressure levels refer to diagram on “Technical information” page. Sound immission and acoustic information on page 10 on.

■ **Information** Page

Technical description	208
Selection chart	209
Design of systems	10 on

■ **Made to order designs**

Alternative voltages, frequencies, protection classes, acid protection, high temperatures etc. are available on request.

For safety and correct use note the technical information on page 15 on.

Type	Ref. no.	R.P.M.	Air flow volume (FID)	Motor power*	Voltage	Current*		Wiring diagram	Maximum air flow temp.		Weight net	5 step transformer controller Pole switch		Full motor protection starter using the motor thermal contacts		Anti vibration mounts	
						standard supply	speed controlled		standard supply	speed controlled		Type	Ref. no.	Type	Ref. no.	comp	susp
			min <sup>-1</sup>	∇ m <sup>3</sup> /h	kW	V	A	A	No.	+°C	+°C	kg			Type	Type	
<b>1 Phase motor, 1 ph. / 50 Hz, protection to IP 54</b>																	
VARW 250/4	6666	1420	1210	0.12	230	0.46	0.60	966	60	40	11.5	MWS 1,5 <sup>1)</sup>	1947	MW	1579	SDD 1	SDZ 1
VARW 250/2	6667	2840	2540	0.55	230	2.60	3.90	966	60	40	13.0	MWS 5 <sup>1)</sup>	1949	MW	1579	SDD 1	SDZ 1
<b>3 Phase motor, 50 Hz, protection to IP 54</b>																	
VARD 250/4	6668	1410	1250	0.09	400	0.30	0.30	469	60	40	11.5	RDS 1 <sup>1) 4)</sup>	1314	MD	5849	SDD 1	SDZ 1
VARD 250/2	6669	2800	2450	0.47	400	1.10	1.10	469	60	40	11.5	RDS 2 <sup>1) 4)</sup>	1315	MD	5849	SDD 1	SDZ 1
<b>Pole-switching, 2 speed motor (Dahlander windings Y/YY), 3 ph. / 50 Hz, protection to IP 54</b>																	
VARW 250/4/2	6773	1425/2750	1200/2400	0.75/0.49	400	0.24/0.94	—	472	60	—	13.0	PDA 12 <sup>3)</sup>	5081	M 3 <sup>2)</sup>	1293	SDD 1	SDZ 1
<b>Explosion proof, E Ex de II B, 1 ph. / 50 Hz, temperature class T1-T3, protection to IP 55</b>																	
VARW 250/4 Ex	6735	1400	1290	0.06	230	0.70	—	757	40	—	13.0	not permitted	—	—	SDD 1	SDZ 1	
<b>Explosion proof, E Exe II, 3 ph. / 50 Hz, temperature class T1-T3, protected to IP 54</b>																	
VARD 250/4 Ex	6670	1400	1300	0.12	400	0.41	—	470	40	—	13.0	not permitted	not permitted	SDD 1	SDZ 1		
VARD 250/2 Ex	6671	2825	2590	0.37	400	0.95	—	470	40	—	15.5	not permitted	not permitted	SDD 1	SDZ 1		

\* Ex models: For nominal value of motor see information on page 16 <sup>1)</sup> includes full motor protection unit <sup>2)</sup> includes operation and speed switch <sup>3)</sup> see product page for flush mounted version <sup>4)</sup> Frequency inverter with integrated Sine filter, Type FU-BS 2.5, No. 5459, see product page FU.

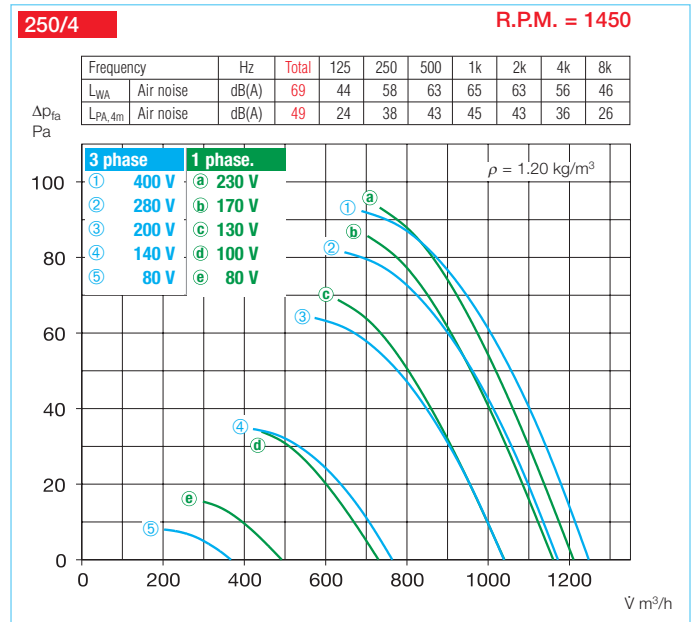
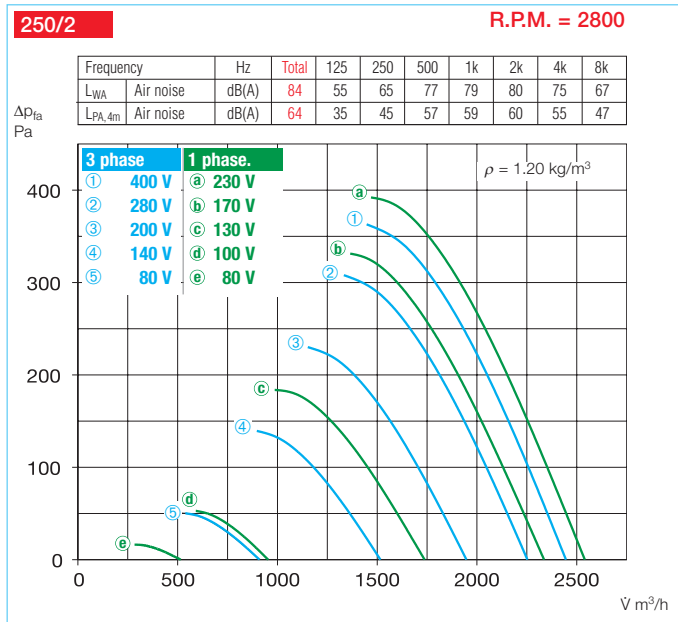

Other accessories	Page
<b>b) Accessories for ex-proof fans</b>	
<b>Flanged flexible connector</b>	
Type STS 250 Ex	Ref. no. 2501
<b>Flexible sleeve</b>	
Type FM 250 Ex	Ref. no. 1688
Attenuators	421 on
Shutters and grilles	487 on
Speed controllers and switches	525 on

Accessories Specification see page 231 on

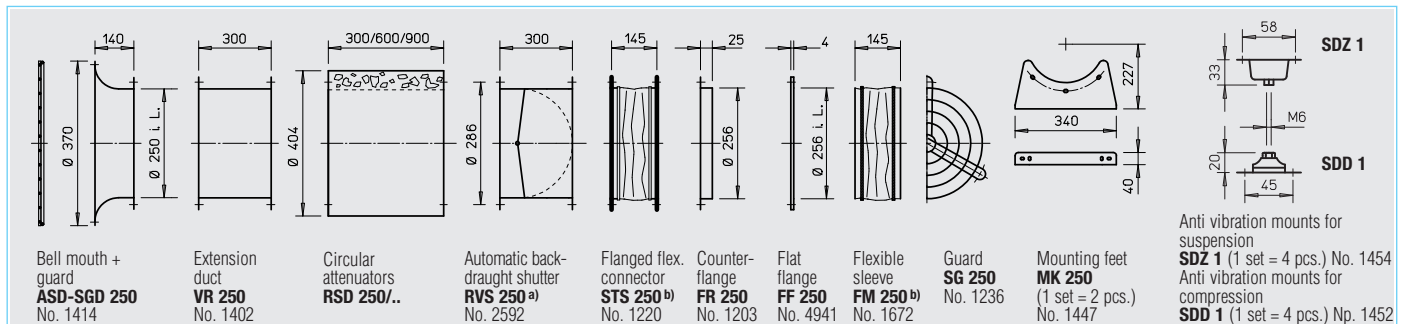

<sup>a)</sup> For motorised shutters see accessory pages

<sup>b)</sup> Types for explosion proof fans see above

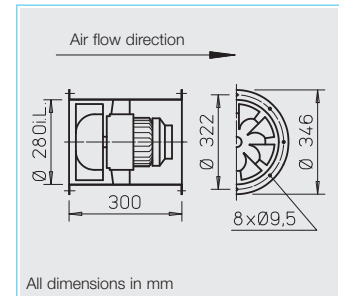

■ **Specification**

□ **Casing**

Manufactured in galvanised sheet steel with flanges on both sides to DIN 24155, Pt. 3, with fixed guide vanes and motor support.

□ **Impeller**

Optimised for high pressure and performance. Specially developed mixed-flow curved impeller manufactured from impact resistant polymers.

□ **Motor**

Direct driven, maintenance free flange motor, totally enclosed with an aluminium casing and cooling fins, protected to IP 54. Sealed for life ball bearings with tropicalized protection of windings and interference-free. Optional drainage holes made to order (please state installation position).

□ **Speed control**

For all speed controllable models the current is given in the “speed controlled” column of the table below which must be used when selecting a controller (see controller column). The air flow volumes can be seen from the characteristic curves. If the fan is to be controlled by a frequency inverter without a sine filter, this must be stated when ordering. This requires a change of fan design and potential additional costs. Explosion proof fans are not controllable.

□ **Electrical connection**

Terminal box fitted externally on the casing as standard (IP 55).

□ **Installation**

Installation in any position. Ensure that motor drainage holes (where used) face downwards.

□ **Motor protection**

All models (3~ except ex proof) have thermal contacts as standard which must be connected to a full motor protection unit (see table below). With the 1 ph. ex-proof models thermal contacts are wired in series with the winding which automatically resets after cooling. Models without thermal contacts must be protected by a conventional circuit breaker.

□ **Sound levels**

Data shown within the performance curves refer to sound power levels. For determination of the lower sound pressure levels refer to diagram on “Technical information” page. Sound emission and acoustic information on page 10 on.

■ **Information** Page

Technical description	208
Selection chart	209
Information for planning	10 on

■ **Made to order designs**

Alternative voltages, frequencies, protection classes, acid protection, high temperatures etc. are available on request.

For safety and correct use note the technical information on page 15 on.

Type	Ref. no.	R.P.M.	Air flow volume (FID)	Motor power*	Voltage	Current*		Wiring diagram	Maximum air flow temp.		Nominal weight (net)	5 step transformer controller Pole switch		Full motor protection starter using the motor thermal contacts		Anti vibration mounts	
						standard supply	speed controlled		standard supply	speed controlled		Type	Ref. no.	Type	Ref. no.	comp	susp
			min <sup>-1</sup>	V m <sup>3</sup> /h	kW	V	A	A	No.	+°C	+°C	kg			Type	Type	
<b>1 Phase motor, 1 ph. / 50 Hz, protection to IP 54</b>																	
VARW 280/4	6672	1330	1600	0.11	230	0.50	0.60	966	60	40	12.0	MWS 1,5 <sup>1)</sup>	1947	MW	1579	SDD 1	SDZ 1
VARW 280/2	6659	2715	3350	0.79	230	3.70	4.90	967	60	40	14.0	MWS 7,5 <sup>1)</sup>	1950	MW	1579	SDD 1	SDZ 1
<b>3 Phase motor, 50 Hz, protection to IP 54</b>																	
VARD 280/4	6673	1370	1650	0.12	400	0.35	0.35	469	60	40	12.0	RDS 1 <sup>1) 4)</sup>	1314	MD	5849	SDD 1	SDZ 1
VARD 280/2	6674	2705	3315	0.80	400	1.52	1.64	469	60	40	13.5	RDS 2 <sup>1) 4)</sup>	1315	MD	5849	SDD 1	SDZ 1
												Pole-switching, 2 speed motor (Dahlander windings Y/YY), 3 ph. / 50 Hz, protection to IP 54					
VARD 280/4/2	6775	1405/2810	1760/3500	0.14/0.91	400	0.44/1.78	—	472	60	—	16.0	PDA 12 <sup>3)</sup>	5081	M 3 <sup>2)</sup>	1293	SDD 1	SDZ 1
<b>Explosion proof, E Ex de II B, 1 ph. / 50 Hz, temperature class T1-T3, protection to IP 55</b>																	
VARW 280/4 Ex	6737	1330	1720	0.18	230	1.25	—	757	40	—	14.0	not permitted	—	—	SDD 1	SDZ 1	
<b>Explosion proof, E Exe II, 3 ph. / 50 Hz, temperature class T1-T3, protected to IP 54</b>																	
VARD 280/4 Ex	6675	1400	1820	0.12	400	0.41	—	470	40	—	16.0	not permitted	not permitted	SDD 1	SDZ 1		
VARD 280/2 Ex	6676	1860	3720	0.75	400	1.65	—	470	40	—	18.0	not permitted	not permitted	SDD 1	SDZ 1		

\* Ex models: For nominal value of motor see information on page 16 <sup>1)</sup> includes full motor protection unit <sup>2)</sup> includes operation and speed switch <sup>3)</sup> see product page for flush mounted version <sup>4)</sup> Frequency inverter with integrated Sine filter, Type FU-BS 2,5, No. 5459, see product page FU.

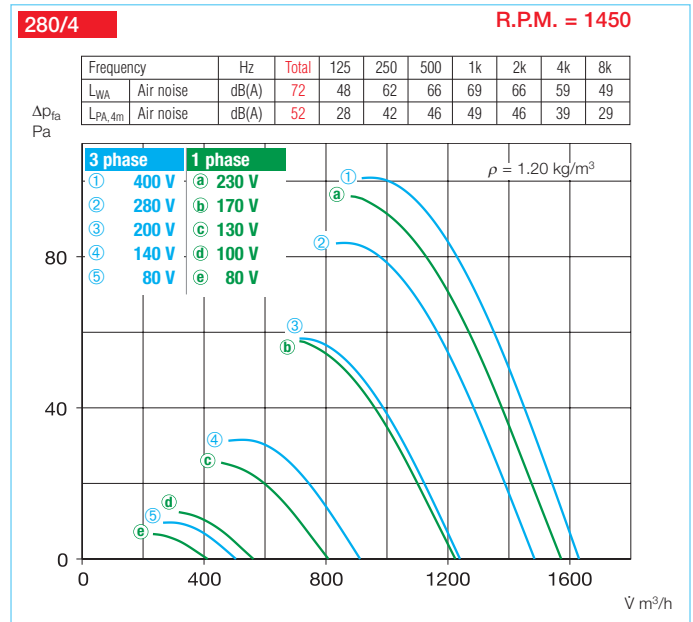
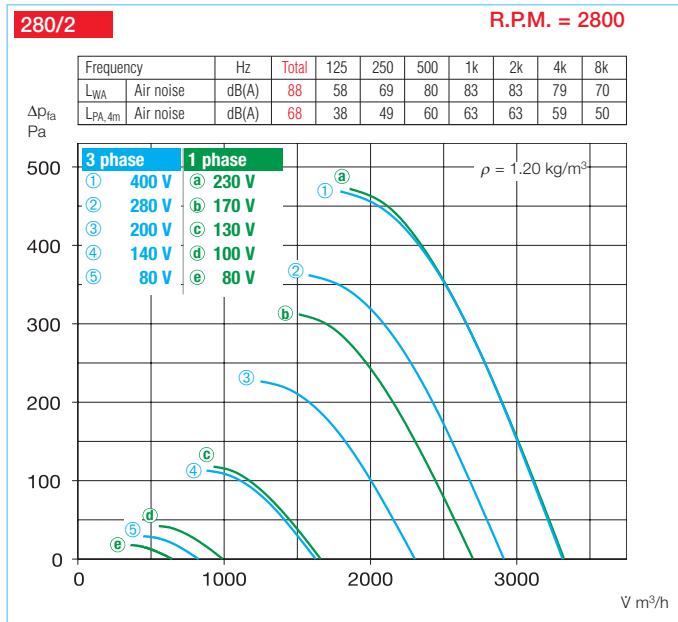

Other accessories	Page
<b>b) Accessories for ex-proof fans</b>	
<b>Flanged flexible connector</b>	
Type STS 280 Ex	Ref. no. 2502
<b>Flexible sleeve</b>	
Type FM 280 Ex	Ref. no. 1689
Attenuators	421 on
Shutters and grilles	487 on
Speed controllers and switches	525 on

Accessories Specification see page 231 on

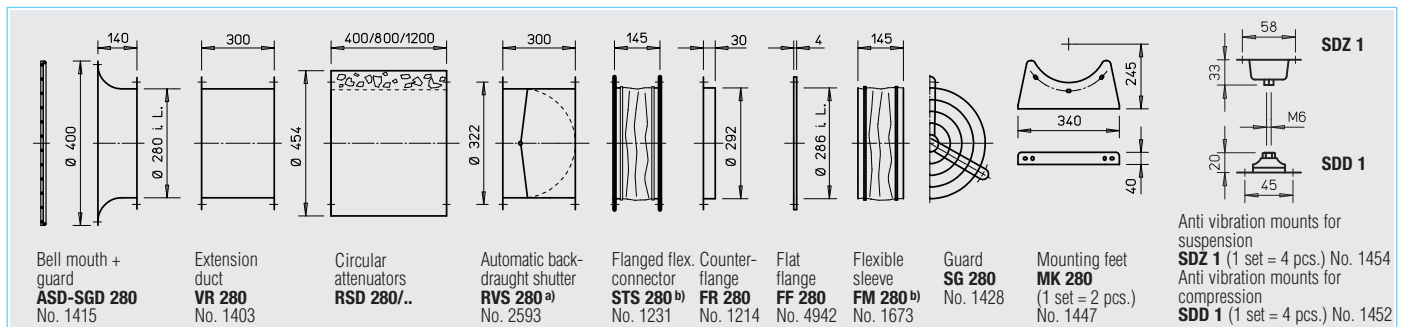

<sup>a)</sup> For motorised shutters see accessory pages

<sup>b)</sup> Types for explosion proof fans see above

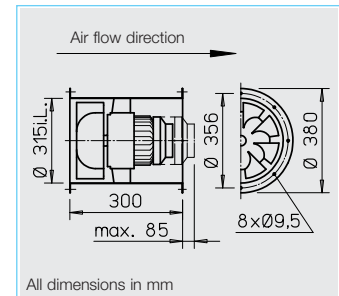

■ **Specification**

□ **Casing**

Manufactured in galvanised sheet steel with flanges on both sides to DIN 24155, Pt. 3, with fixed guide vanes and motor support.

□ **Impeller**

Optimised for high pressure and performance. Specially developed mixed-flow curved impeller manufactured from impact resistant polymers.

□ **Motor**

Direct driven, maintenance free flange motor, totally enclosed with an aluminium casing and cooling fins, protected to IP 54. Sealed for life ball bearings with tropicalized protection of windings and interference-free. Optional drainage holes made to order (please state installation position).

□ **Speed control**

For all speed controllable models the current is given in the “speed controlled” column of the table below which must be used when selecting a controller (see controller column). The air flow volumes can be seen from the characteristic curves. If the fan is to be controlled by a frequency inverter without a sine filter, this must be stated when ordering. This requires a change of fan design and potential additional costs. Explosion proof fans are not controllable.

□ **Electrical connection**

Terminal box fitted externally on the casing as standard (IP 55).

□ **Installation**

Installation in any position. Ensure that motor drainage holes (where used) face downwards.

□ **Motor protection**

All models (3~ except ex proof) have thermal contacts as standard which must be connected to a full motor protection unit (see table below). With the 1 ph. ex-proof models thermal contacts are wired in series with the winding which automatically resets after cooling. Models without thermal contacts must be protected by a conventional circuit breaker.

□ **Sound levels**

Data shown within the performance curves refer to sound power levels. For determination of the lower sound pressure levels refer to diagram on “Technical information” page. Sound emission and acoustic information on page 10 on.

■ **Information** Page

Technical description	208
Selection chart	209
Information for planning	10 on

■ **Made to order designs**

Alternative voltages, frequencies, protection classes, acid protection, high temperatures etc. are available on request.

For safety and correct use note the technical information on page 15 on.

Type	Ref. no.	R.P.M.	Air flow volume (FID)	Motor power*	Voltage	Current*		Wiring diagram	Maximum air flow temp.		Nominal weight (net)	5 step transformer controller Pole switch		Full motor protection starter using the motor thermal contacts		Anti vibration mounts	
						standard supply	speed controlled		standard supply	speed controlled		Type	Ref. no.	Type	Ref. no.	comp	susp
			min <sup>-1</sup>	∇ m <sup>3</sup> /h	V	A	A	No.	+°C	+°C	kg			Type	Type	Type	Type
<b>1 Phase motor, 1 ph. / 50 Hz, protection to IP 54</b>																	
VARW 315/4	6677	1440	2480	0.23	230	1.10	1.17	966	60	40	13.0	MWS 3 <sup>1)</sup>	1948	MW	1579	SDD 1	SDZ 1
<b>3 Phase motor, 50 Hz, protection to IP 54</b>																	
VARD 315/4	6678	1450	2510	0.22	400	0.60	0.70	469	60	40	13.0	RDS 1 <sup>1) 4)</sup>	1314	MD	5849	SDD 1	SDZ 1
<b>Two-speed, 3 ph., 50 Hz, Y/Δ switch, protection to IP 54</b>																	
VARD 315/2/2	6679	1520/2650	2921/4670	1.29/1.35	400Y/Δ	1.5/2.75	2.8	520	60	40	20.5	RDS 4 <sup>1)</sup>	1316	M 4 <sup>2)</sup>	1571	SDD 1	SDZ 1
													Pole-switching, 2 speed motor (Dahlander windings Y/YY), 3 ph. / 50 Hz, protection to IP 54				
VARD 315/4/2	6777	1480/2890	2730/5340	0.42/1.83	400	1.2/3.3	—	472	60	—	20.5	PDA 12 <sup>3)</sup>	5081	M 3 <sup>2)</sup>	1293	SDD 1	SDZ 1
<b>Explosion proof, E Ex de II B, 1 ph. / 50 Hz, temperature class T1-T3, protection to IP 55</b>																	
VARW 315/4 Ex	6738	1450	2680	0.18	230	1.25	—	757	40	—	15.0	not permitted	—	—	SDD 1	SDZ 1	
<b>Explosion proof, E Exe II, 3 ph. / 50 Hz, temperature class T1-T3, protected to IP 54</b>																	
VARD 315/4 Ex	6680	1420	2610	0.37	400	1.14	—	470	40	—	17.0	not permitted	not permitted	SDD 1	SDZ 1		
VARD 315/2 Ex	6681	2860	5260	1.50	400	3.15	—	470	40	—	23.0	not permitted	not permitted	SDD 1	SDZ 1		

\* Ex models: For nominal value of motor see information on page 16 <sup>1)</sup> includes full motor protection unit <sup>2)</sup> includes operation and speed switch <sup>3)</sup> see product page for flush mounted version

<sup>4)</sup> Frequency inverter with integrated Sine filter, Type FU-BS 2.5, No. 5459, see product page FU.

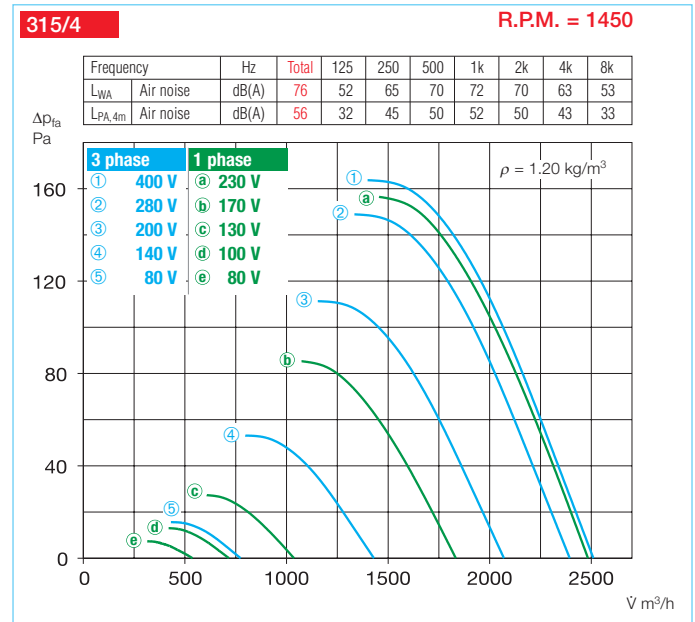
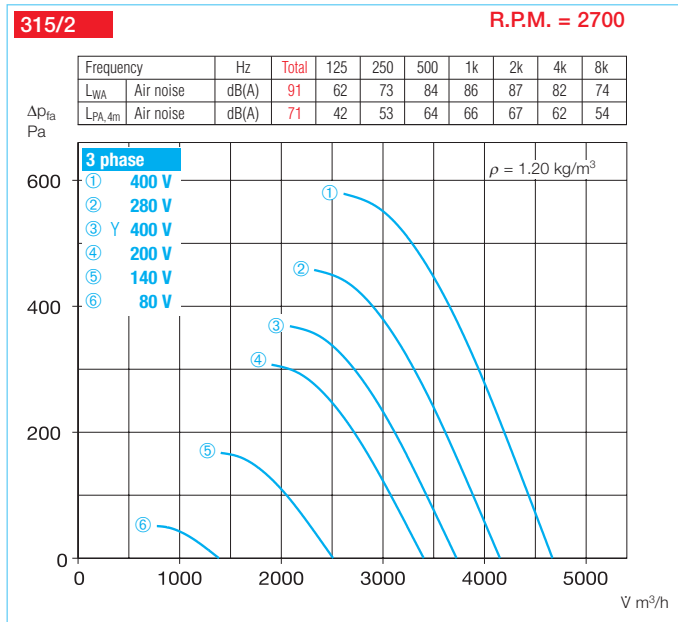

Other accessories	Page
<b>b) Accessories for ex-proof fans</b>	
<b>Flanged flexible connector</b>	
Type STS 315 Ex	Ref. no. 2503
<b>Flexible sleeve</b>	
Type FM 315 Ex	Ref. no. 1690
Attenuators	421 on
Shutters and grilles	487 on
Speed controllers and switches	525 on

**Accessories** Specification see page 231 on

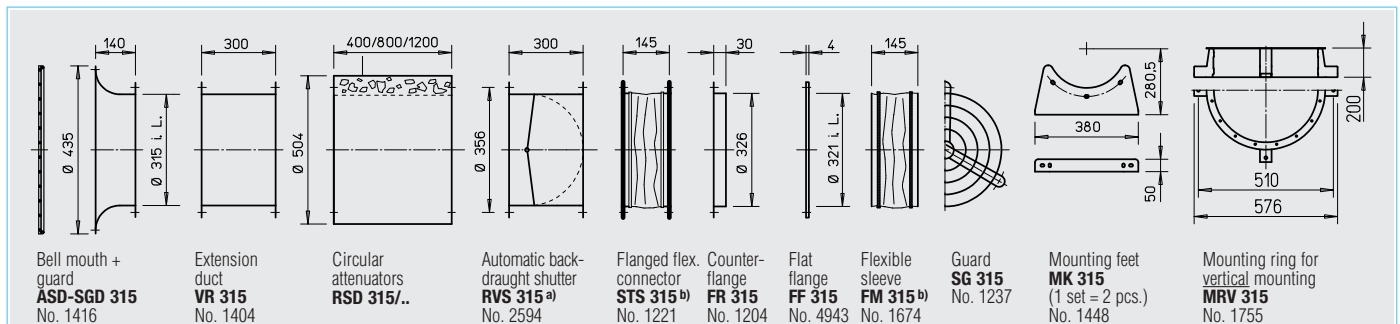

a) For motorised shutters see accessory pages

b) Types for explosion proof fans see above

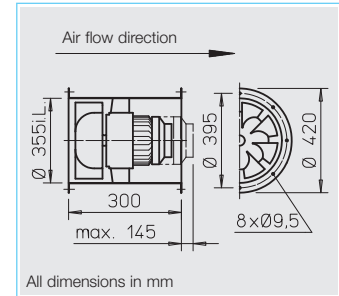

**■ Specification**

**□ Casing**

Manufactured in galvanised sheet steel with flanges on both sides to DIN 24155, Pt. 3, with fixed guide vanes and motor support.

**□ Impeller**

Optimised for high pressure and performance. Specially developed mixed-flow curved impeller manufactured from impact resistant polymers (models with R.P.M. = 2800 from hot dipped galvanised steel).

**□ Motor**

Direct driven, maintenance free flange motor, totally enclosed with an aluminium casing and cooling fins, protected to IP 54. Sealed for life ball bearings with tropicalized protection of windings and interference-free. Optional drainage holes made to order (please state installation position).

**□ Speed control**

For all speed controllable models the current is given in the “speed controlled” column of the table below which must be used when selecting a controller (see controller column). The air flow volumes can be seen from the characteristic curves. If the fan is to be controlled by a frequency inverter without a sine filter, this must be stated when ordering. This requires a change of fan design and potential additional costs. Explosion proof fans are not controllable.

**□ Electrical connection**

Terminal box fitted externally on the casing as standard (IP 55).

**□ Installation**

Installation in any position. Ensure that motor drainage holes (where used) face downwards.

**□ Motor protection**

All models (excluding ex-proof models and model VARD 355/4/2) have thermal contacts as standard which must be connected to a full motor protection unit (see table below) for effective motor protection. Models without thermal contacts must be protected by a conventional circuit breaker.

**□ Sound levels**

Data shown within the performance curves refer to sound power levels. For determination of the lower sound pressure levels refer to diagram on “Technical information” page. Sound emission and acoustic information on page 10 on.

**■ Information Page**

Technical description	208
Selection chart	209
Information for planning	10 on

**Made to order designs**

Alternative voltages, frequencies, protection classes, acid protection, high temperatures etc. are available on request.

For safety and correct use note the technical information on page 15 on.

Type	Ref. no.	R.P.M.	Air flow volume (FID)	Motor power*	Voltage	Current*		Wiring diagram	Maximum air flow temp. standard supply	speed controlled	Nominal weight (net)	5 step transformer controller Pole switch		Full motor protection starter using the motor thermal contacts		Anti vibration mounts		
						standard supply	speed controlled					Type	Ref. no.	Type	Ref. no.	comp	susp	
			min <sup>-1</sup>	V m <sup>3</sup> /h	kW	V	A	A	No.	+°C	+°C	kg	Type	Ref. no.	Type	Ref. no.	Type	Type
<b>1 Phase motor, 1 ph. / 50 Hz, protection to IP 54</b>																		
<b>VARW 355/4</b>	6682	1380	3470	0.37	230	3.30	2.35	966	60	40	21.0	<b>MWS 3<sup>1)</sup></b>	1948	<b>MW</b>	1579	<b>SDD 1</b>	<b>SDZ 1</b>	
<b>3 Phase motor, 50 Hz, protection to IP 54</b>																		
<b>VARD 355/4</b>	6683	1440	3550	0.40	400	0.87	1.20	469	60	40	15.5	<b>RDS 1<sup>1) 5)</sup></b>	1314	<b>MD</b>	5849	<b>SDD 1</b>	<b>SDZ 1</b>	
<b>Two-speed, 3 ph., 50 Hz, Y/Δ switch, protection to IP 54</b>																		
<b>VARD 355/2/2</b>	6684	2415/2790	6040/7220	2.06/2.81	400Y/Δ	3.40/5.40	—	520	60	30	21.5	<b>RDS 7<sup>1)</sup></b>	1578	<b>M 4<sup>2)</sup></b>	1571	<b>SDD 1</b>	<b>SDZ 1</b>	
												Pole switch						
<b>VARD 355/4/2</b>	6779	1470/2870	3830/7500	0.48/3.11	400	1.35/5.50	—	471	40	—	29.0	<b>PDA 12<sup>3)</sup></b>	5081	<b>M 3<sup>2)</sup></b>	1293	<b>SDD 1</b>	<b>SDZ 1</b>	
<b>Explosion proof, E Exe II, 3 ph. / 50 Hz, temperature class T1-T3, protected to IP 54</b>																		
<b>VARD 355/4 Ex</b>	6685	1420	3740	0.37	400	1.14	—	470	40	—	19.0	not permitted	not permitted	<b>SDD 1</b>	<b>SDZ 1</b>			
<b>VARD 355/2 Ex<sup>4)</sup></b>	6686	2860	7580	2.50	400	4.85/2.77	—	498	40	—	33.0	not permitted	not permitted	<b>SDD 1</b>	<b>SDZ 1</b>			

\* Ex models: For nominal value of motor see information on page 16 <sup>1)</sup> includes full motor protection unit <sup>2)</sup> includes operation and speed switch <sup>3)</sup> see product page for flush mounted version

<sup>4)</sup> Vibration monitoring is necessary (on site) pursuant to DIN EN 14986. <sup>5)</sup> Frequency inverter with integrated Sine filter, Type FU-BS 2,5, No. 5459, see product page FU.

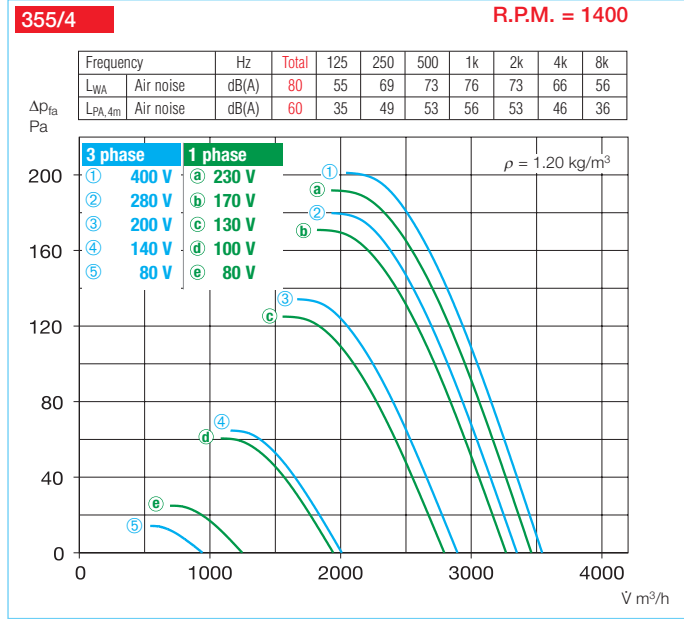
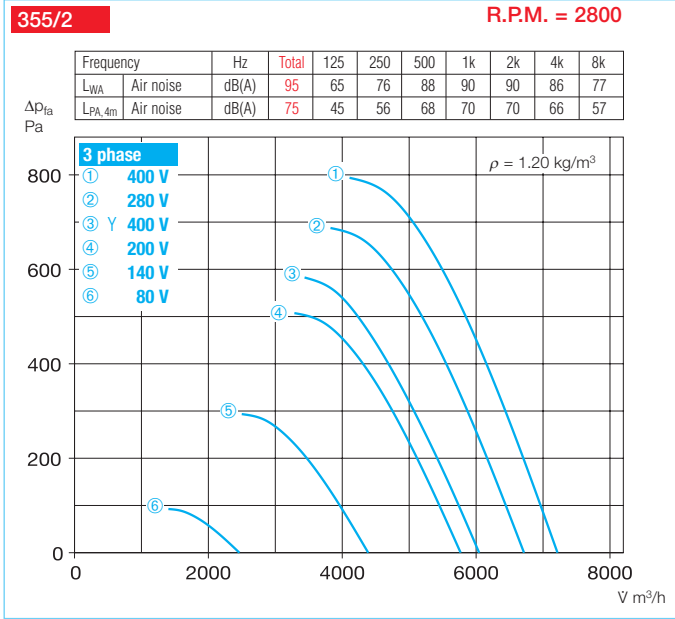

Other accessories	Page
<b>b) Accessories for ex-proof fans</b>	
<b>Flanged flexible connector</b>	
Type STS 355 Ex	Ref. no. 2504
<b>Flexible sleeve</b>	
Type FM 355 Ex	Ref. no. 1691
Attenuators	421 on
Shutters and grilles	487 on
Speed controllers and switches	525 on

Accessories Specification see page 231 on

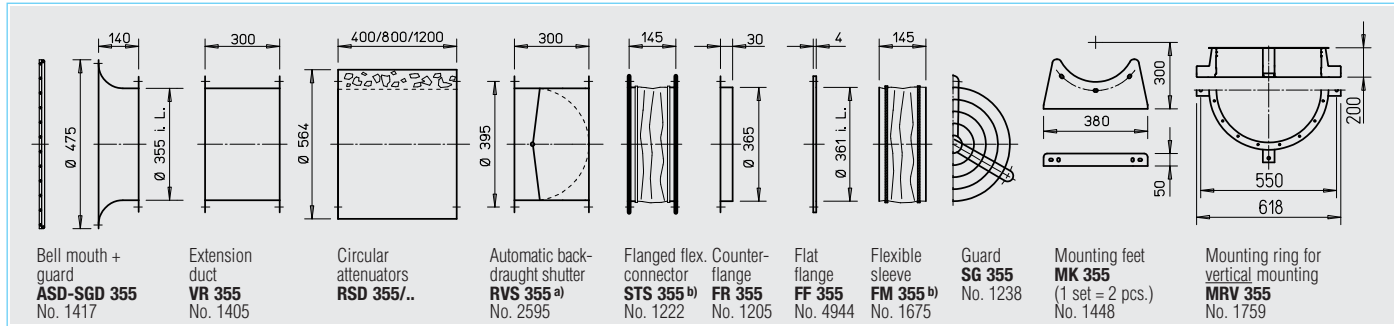

<sup>a)</sup> For motorised shutters see accessory pages

<sup>b)</sup> Types for explosion proof fans see above

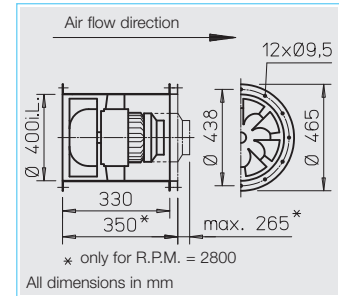

**■ Specification**

**□ Casing**

Manufactured in galvanised steel with flanges on both sides to DIN 24155, Pt. 3, vanes and fixed motor support. Models with R.P.M. = 2800 with welded casing made from hot dipped galvanised steel.

**□ Impeller**

Optimised for high pressure and performance. Specially developed mixed-flow curved impeller manufactured from hot dipped galvanised steel.

**□ Motor**

Direct driven, maintenance free flange motor, totally enclosed with an aluminium casing and cooling fins, protected to IP 54. Sealed for life ball bearings with tropicalized protection of windings and interference-free. Optional drainage holes made to order (please state installation position).

**□ Speed control**

For all speed controllable models the current is given in the “speed controlled” column of the table below which must be used when selecting a controller (see controller column). The air flow volumes can be seen from the characteristic curves. If the fan is to be controlled by a frequency inverter without a sine filter, this must be stated when ordering. This requires a change of fan design and potential additional costs. Explosion proof fans are not controllable.

**□ Electrical connection**

Terminal box fitted externally on the casing as standard (IP 55).

**□ Installation**

Installation in any position. Ensure that motor drainage holes (where used) face downwards.

**□ Motor protection**

All models (excluding ex-proof models and model VARD 400/4/2) have thermal contacts as standard which must be connected to a full motor protection unit (see table below) for effective motor protection. Models without thermal contacts must be protected by a conventional circuit breaker.

**□ Sound levels**

Data shown within the performance curves refer to sound power levels. For determination of the lower sound pressure levels refer to diagram on “Technical information” page. Sound emission and acoustic information on page 10 on.

**■ Information Page**

Technical description	208
Selection chart	209
Information for planning	10 on

**Made to order designs**

Alternative voltages, frequencies, protection classes, acid protection, high temperatures etc. are available on request.

For safety and correct use note the technical information on page 15 on.

Type	Ref. no.	R.P.M.	Air flow volume (FID)	Motor power*	Voltage	Current*		Wiring diagram	Maximum air flow temp.		Nominal weight (net)	5 step transformer controller Pole switch		Full motor protection starter using the motor thermal contacts		Anti vibration mounts	
						standard supply	speed controlled		standard supply	speed controlled		Type	Ref. no.	Type	Ref. no.	comp	susp
		min <sup>-1</sup>	V m <sup>3</sup> /h	kW	V	A	A	No.	+°C	+°C	kg	Type	Ref. no.	Type	Ref. no.	Type	Type
<b>1 Phase motor, 1 ph. / 50 Hz, protection to IP 54</b>																	
VARW 400/4	6688	1375	5130	0.70	230	3.00	3.35	967	60	40	22.5	MWS 5 <sup>1)</sup>	1949	MW	1579	SDD 1	SDZ 1
<b>3 Phase motor, 50 Hz, protection to IP 54</b>																	
VARD 400/4	6690	1400	5240	0.72	400	1.95	2.00	469	60	40	22.5	RDS 4 <sup>1) 5)</sup>	1316	MD	5849	SDD 1	SDZ 1
<b>Two-speed, 3 ph., 50 Hz, Y/Δ switch, protection to IP 54</b>																	
VARD 400/2/2	6691	2475/2800	8320/10610	3.63/4.95	400Y/Δ	5.75/7.95	—	520	60	40	74.0	RDS 11 <sup>1)</sup>	1332	M 4 <sup>2)</sup>	1571	SDD 1	SDZ 2
												Pole switch					
<b>Pole-switching, 2 speed motor (Dahlander windings Y/YY), 3 ph. / 50 Hz, protection to IP 54</b>																	
VARD 400/4/2	6782	1400/2890	5220/10700	0.80/5.90	400	2.43/9.13	—	471	40	—	74.0	PDA 12 <sup>3)</sup>	5081	M 3 <sup>2)</sup>	1293	SDD 1	SDZ 2
<b>Explosion proof, E Exe II, 3 ph. / 50 Hz, temperature class T1-T3, protected to IP 54</b>																	
VARD 400/6 Ex	6692	920	3465	0.25	400	0.97	—	470	40	—	21.0	not permitted	not permitted	SDD 1	SDZ 1		
VARD 400/4 Ex	6693	1400	5360	0.55	400	1.51	—	470	40	—	25.0	not permitted	not permitted	SDD 1	SDZ 1		
VARD 400/2 Ex <sup>4)</sup>	6694	2895	10950	4.60	400	8.20	—	498	40	—	83.0	not permitted	not permitted	SDD 2	SDZ 2		

\* Ex models: For nominal value of motor see information on page 16 <sup>1)</sup> includes full motor protection unit <sup>2)</sup> includes operation and speed switch <sup>3)</sup> see product page for flush mounted version

<sup>4)</sup> Vibration monitoring is necessary (on site) pursuant to DIN EN 14986. <sup>5)</sup> Frequency inverter with integrated Sine filter, Type FU-BS 2.5, No. 5459, see product page FU.

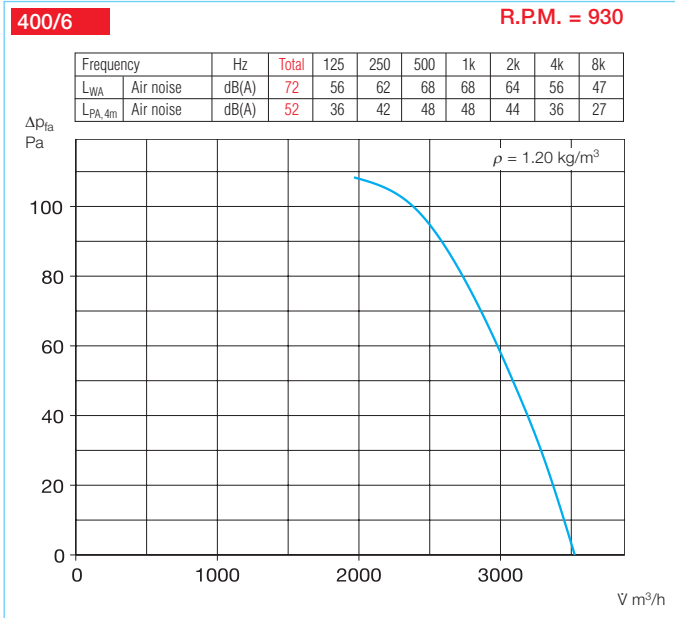
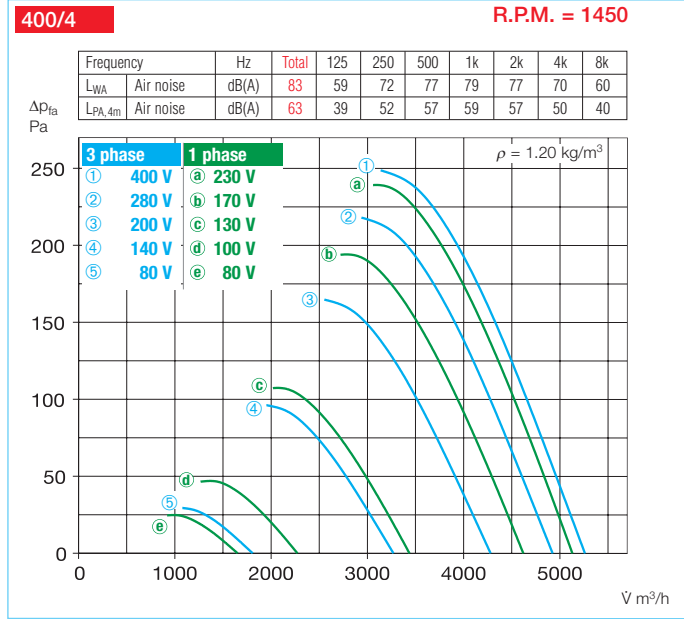
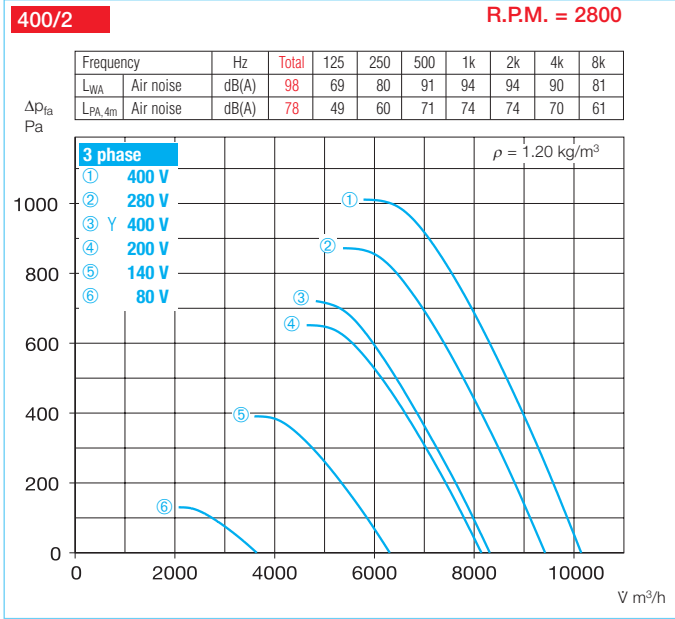

Other accessories	Page
<b>Accessories for ex-proof fans</b>	
Flanged flexible connector Type STS 400 Ex	Ref. no. 2505
Flexible sleeve Type FM 400 Ex	Ref. no. 1692
Attenuators	421 on
Shutters and grilles	487 on
Speed controllers and switches	525 on

**Accessories** Specification see page 231 on

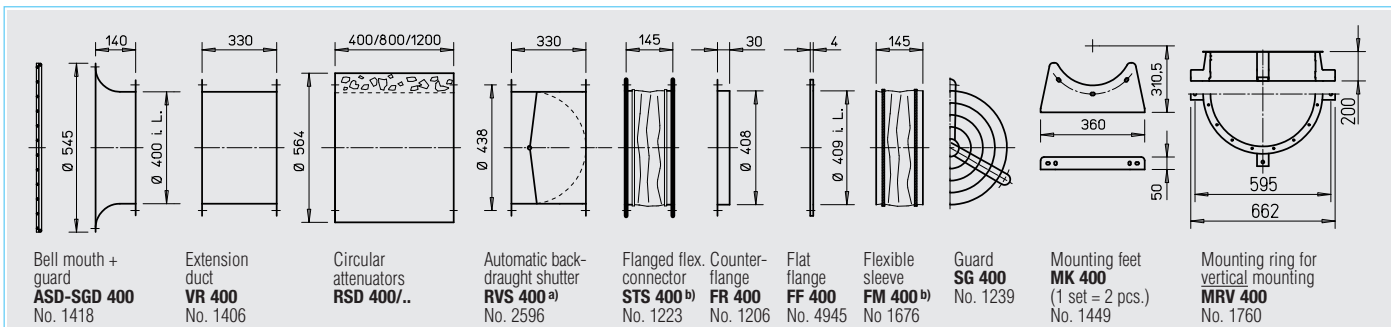

<sup>a)</sup> For motorised shutters see accessory pages

<sup>b)</sup> Types for explosion proof fans see left page

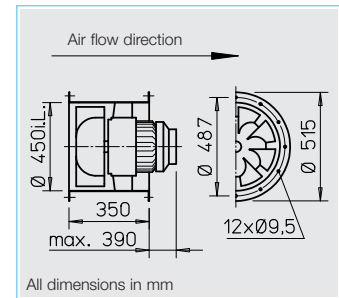

■ **Specification**

□ **Casing**

Manufactured in galvanised steel with flanges on both sides to DIN 24155, Pt. 3, vanes and fixed motor support. Models with R.P.M. = 2800 with welded casing made from hot dipped galvanised steel.

□ **Impeller**

Optimised for high pressure and performance. Specially developed mixed-flow curved impeller manufactured from hot dipped galvanised steel.

□ **Motor**

Direct driven, maintenance free flange motor, totally enclosed with an aluminium casing and cooling fins, protected to IP 54. Sealed for life ball bearings with tropicalized protection of windings and interference-free. Optional drainage holes made to order (please state installation position).

□ **Speed control**

For all speed controllable models the current is given in the "speed controlled" column of the table below which must be used when selecting a controller (see controller column). The air flow volumes can be seen from the characteristic curves. If the fan is to be controlled by a frequency inverter without a sine filter, this must be stated when ordering. This requires a change of fan design and potential additional costs. Explosion proof fans are not controllable.

□ **Electrical connection**

Terminal box fitted externally on the casing as standard (IP 55).

□ **Installation**

Installation in any position. Ensure that motor drainage holes (where used) face downwards.

□ **Motor protection**

All models (excluding ex-proof models) have thermal contacts and PTC Thermistors as standard which must be connected to a full motor protection unit (see table below) for effective motor protection. Models without thermal contacts must be protected by a conventional circuit breaker.

□ **Sound levels**

Data shown within the performance curves refer to sound power levels. For determination of the lower sound pressure levels refer to diagram on "Technical information" page. Sound emission and acoustic information on page 10 on.

■ **Information** Page

Technical description	208
Selection chart	209
Information for planning	10 on

■ **Made to order designs**

Alternative voltages, frequencies, protection classes, acid protection, high temperatures etc. are available on request.

For safety and correct use note the technical information on page 15 on.

Type	Ref. no.	R.P.M.	Air flow volume (FID)	Motor power*	Voltage	Current*		Wiring diagram	Maximum air flow temp.		Nominal weight (net)	5 step transformer controller Pole switch		Full motor protection starter using the motor thermal contacts		Anti vibration mounts	
						standard supply	speed controlled		standard supply	speed controlled		kg	Type	Ref. no.	Type	Ref. no.	comp
			min <sup>-1</sup>	V m <sup>3</sup> /h	V	A	A	No.	+°C	+°C		Type	Ref. no.	Type	Ref. no.	Type	Type
<b>1 Phase motor, 1 ph. / 50 Hz, protection to IP 54</b>																	
<b>VARW 450/4</b>	6736	1330	7180	1.47	230	6.50	7.00	968	60	40	45.0	<b>MWS 7,5<sup>1)</sup></b>	1950	<b>MW</b>	1579	<b>SDD 1</b>	<b>SDZ 1</b>
<b>3 Phase motor, 50 Hz, protection to IP 54</b>																	
<b>VARD 450/2</b>	6698	2950	14210	8.03	400	13.8	—	776	60	—	95.0	<b>FU-CS18<sup>1)5)</sup></b>	5469	<b>MSA<sup>3)</sup></b>	1289	<b>SDD 2</b>	<b>SDZ 2</b>
<b>Two-speed, 3 ph., 50 Hz, Y/Δ switch, protection to IP 54</b>																	
<b>VARD 450/4 Ex</b>	6697	1100/1370	5930/7390	0.74/1.00	400Y/Δ	1.2/2.3	2.3	520	60	40	45.0	<b>RDS 4<sup>1)</sup></b>	1316	<b>M 4<sup>2)</sup></b>	1571	<b>SDD 1</b>	<b>SDZ 1</b>
<b>Explosion proof, E Exe II, 3 ph. / 50 Hz, temperature class T1-T3, protected to IP 54</b>																	
<b>VARD 450/6 Ex</b>	6699	900	5020	0.25	400	0.99	—	470	40	—	48.0	not permitted	not permitted			<b>SDD 1</b>	<b>SDZ 1</b>
<b>VARD 450/4 Ex</b>	6700	1425	7640	1.10	400	2.55	—	470	40	—	51.0	not permitted	not permitted			<b>SDD 1</b>	<b>SDZ 1</b>
<b>VARD 450/2 Ex<sup>4)</sup></b>	6701	2930	15810	7.50	400	14.10	—	498	40	—	155.0	not permitted	not permitted			<b>SDD 2</b>	<b>SDZ 2</b>

\* Ex models: For nominal value of motor see information on page 16 <sup>1)</sup> includes full motor protection unit <sup>2)</sup> includes operation and speed switch <sup>3)</sup> for PTC Thermistor temp. sensor

<sup>4)</sup> Vibration monitoring is necessary (on site) pursuant to DIN EN 14986. <sup>5)</sup> with integrated Sine filter, see product page FU

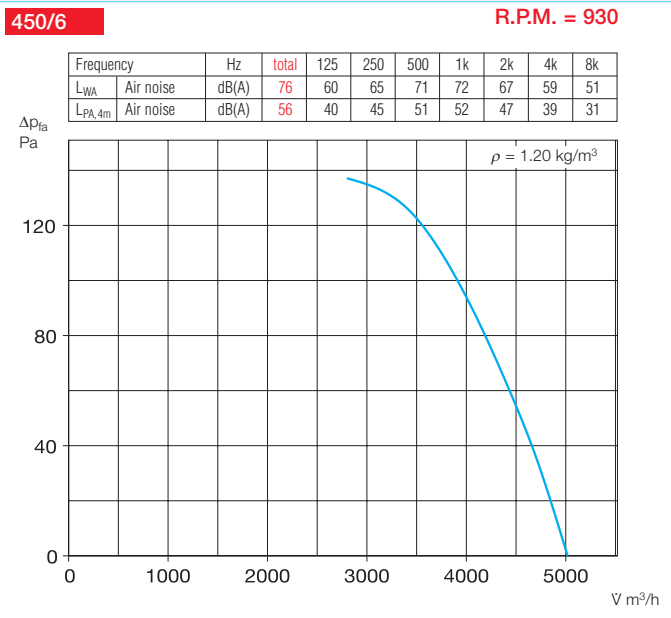
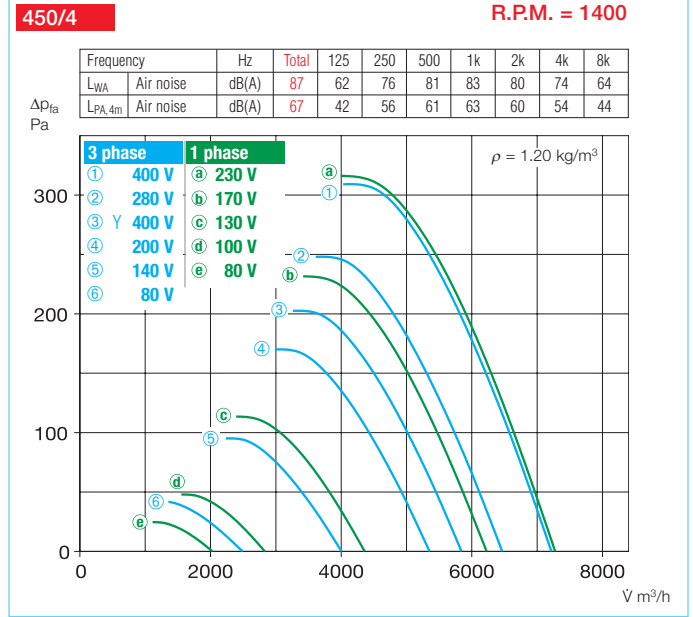
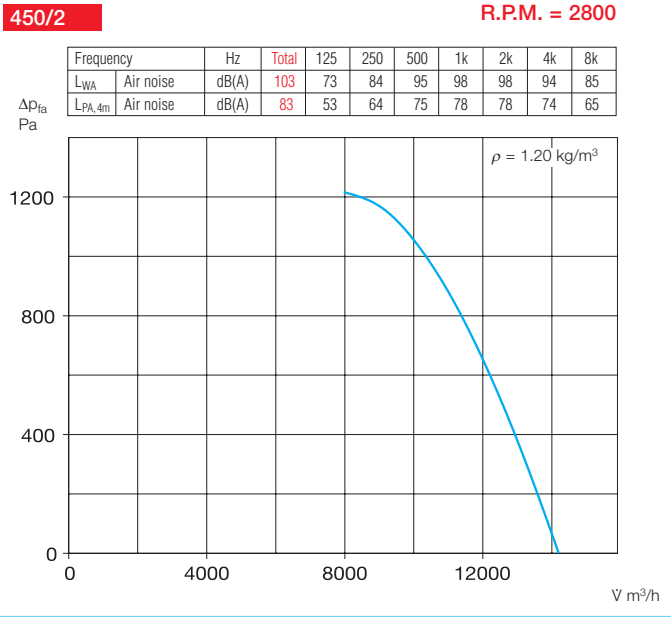

Other accessories	Page
<b>Accessories for ex-proof fans</b>	
Flanged flexible connector Type STS 450 Ex Ref. no. 2506	
Flexible sleeve Type FM 450 Ex Ref. no. 1693	
Attenuators	421 on
Shutters and grilles	487 on
Speed controllers and switches	525 on

Accessories Specification see page 231 on

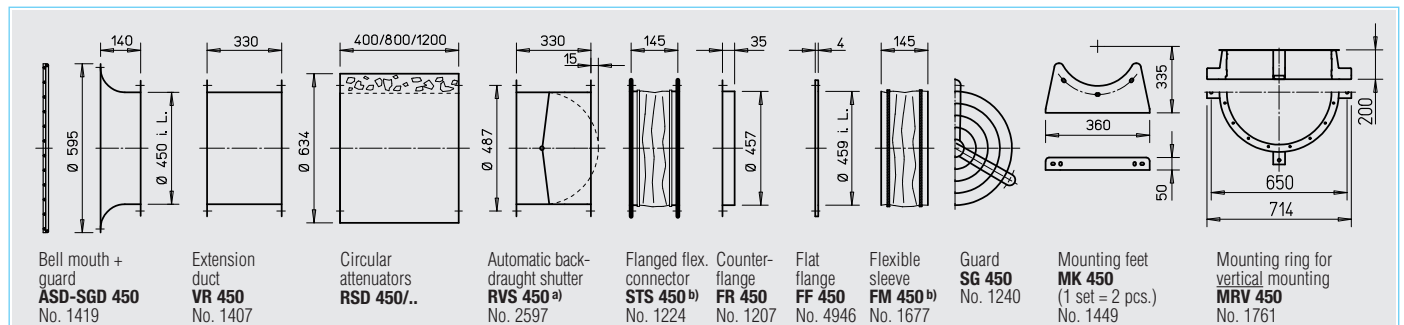

a) For motorised shutters see accessory pages

b) Types for explosion proof fans see left page

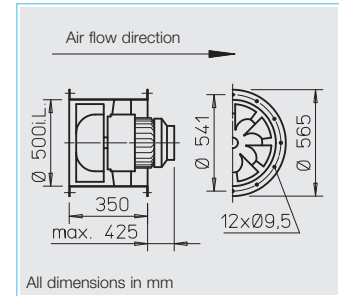

■ **Specification**

□ **Casing**

Manufactured in galvanised steel with flanges on both sides to DIN 24155, Pt. 3, vanes and fixed motor support. Models with R.P.M. = 2800 with welded casing made from hot dipped galvanised steel.

□ **Impeller**

Optimised for high pressure and performance. Specially developed mixed-flow curved impeller manufactured from hot dipped galvanised steel.

□ **Motor**

Direct driven, maintenance free flange motor, totally enclosed with an aluminium casing and cooling fins, protected to IP 54. Sealed for life ball bearings with tropicalized protection of windings and interference-free. Optional drainage holes made to order (please state installation position).

□ **Speed control**

For all speed controllable models the current is given in the “speed controlled” column of the table below which must be used when selecting a controller (see controller column). The air flow volumes can be seen from the characteristic curves. If the fan is to be controlled by a frequency inverter without a sine filter, this must be stated when ordering. This requires a change of fan design and potential additional costs. Explosion proof fans are not controllable.

□ **Electrical connection**

Terminal box fitted externally on the casing as standard (IP 55).

□ **Installation**

Installation in any position. Ensure that motor drainage holes (where used) face downwards.

□ **Motor protection**

All models (excluding ex-proof models) have thermal contacts and PTC Thermistors as standard which must be connected to a full motor protection unit (see table below) for effective motor protection. Models without thermal contacts must be protected by a conventional circuit breaker.

□ **Sound levels**

Data shown within the performance curves refer to sound power levels. For determination of the lower sound pressure levels refer to diagram on “Technical information” page. Sound emission and acoustic information on page 10 on.

■ **Information** Page

Technical description	208
Selection chart	209
Information for planning	10 on

**Made to order designs**

Alternative voltages, frequencies, protection classes, acid protection, high temperatures etc. are available on request.

For safety and correct use note the technical information on page 15 on.

Type	Ref. no.	R.P.M.	Air flow volume (FID) V m³/h	Motor power* kW	Voltage V	Current*		Wiring diagram No.	Maximum air flow temp.		Nominal weight (net) kg	5 step transformer controller Pole switch		Full motor protection starter using the motor thermal contacts		Anti vibration mounts	
		min <sup>-1</sup>				standard supply A	speed controlled A		+°C	+°C		Type	Ref. no.	Type	Ref. no.	comp	susp
<b>1 Phase motor, 1 ph. / 50 Hz, protection to IP 54</b>																	
<b>VARW 500/4</b>	6739	1340	9920	2.02	230	9.10	9.10	968	60	40	70.0	<b>MWS 10<sup>1)</sup></b>	1946	<b>MW</b>	1579	<b>SDD 2</b>	<b>SDZ 2</b>
<b>3 Phase motor, 50 Hz, protection to IP 54</b>																	
<b>VARD 500/2</b>	6705	2935	21730	15.70	400	29/16.7	—	776	60	—	180.0	<b>FU-CS32<sup>1)5)</sup></b>	5471	<b>MSA<sup>3)</sup></b>	1289	<b>SDD 2</b>	<b>SDZ 3</b>
<b>Two-speed, 3 ph., 50 Hz, Y/Δ switch, protection to IP 54</b>																	
<b>VARD 500/4/4</b>	6704	1120/1370	8360/10070	1.2/1.8	400Y/Δ	2.1/3.9	3.9	520	60	40	70.0	<b>RDS 7<sup>1)</sup></b>	1578	<b>M 4<sup>2)</sup></b>	1571	<b>SDD 2</b>	<b>SDZ 2</b>
<b>Explosion proof, E Exe II, 3 ph. / 50 Hz, temperature class T1-T3, protected to IP 54</b>																	
<b>VARD 500/6 Ex</b>	6706	930	6810	0.55	400	1.83	—	470	40	—	70.0	not permitted		not permitted		<b>SDD 2</b>	<b>SDZ 2</b>
<b>VARD 500/4 Ex</b>	6707	1420	10470	2.00	400	4.65	—	470	40	—	75.0	not permitted		not permitted		<b>SDD 2</b>	<b>SDZ 2</b>
<b>VARD 500/2 Ex<sup>4)</sup></b>	6708	2930	21760	12.50	400	23.50	—	498	40	—	215.0	not permitted		not permitted		<b>SDD 3</b>	<b>SDZ 3</b>

\* Ex models: For nominal value of motor see information on page 16 <sup>1)</sup> includes full motor protection unit <sup>2)</sup> includes operation and speed switch <sup>3)</sup> for PTC Thermistor temp. sensor  
<sup>4)</sup> Vibration monitoring is necessary (on site) pursuant to DIN EN 14986. <sup>5)</sup> with integrated Sine filter, see product page FU

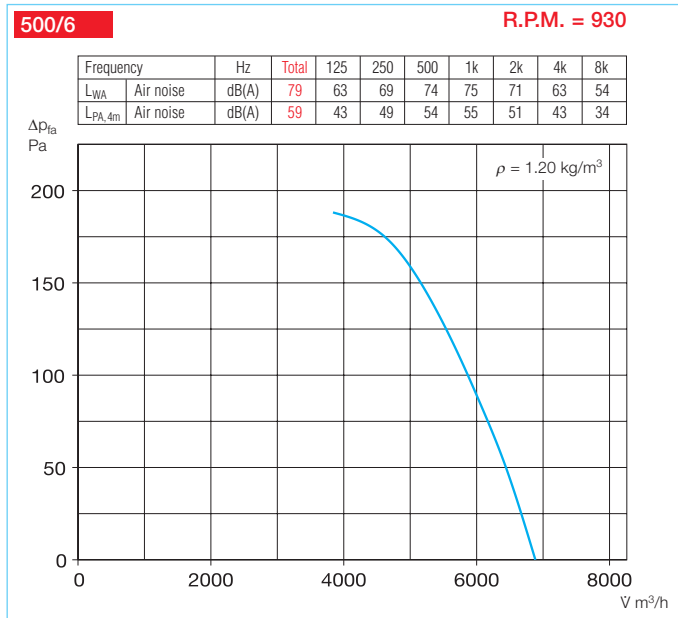
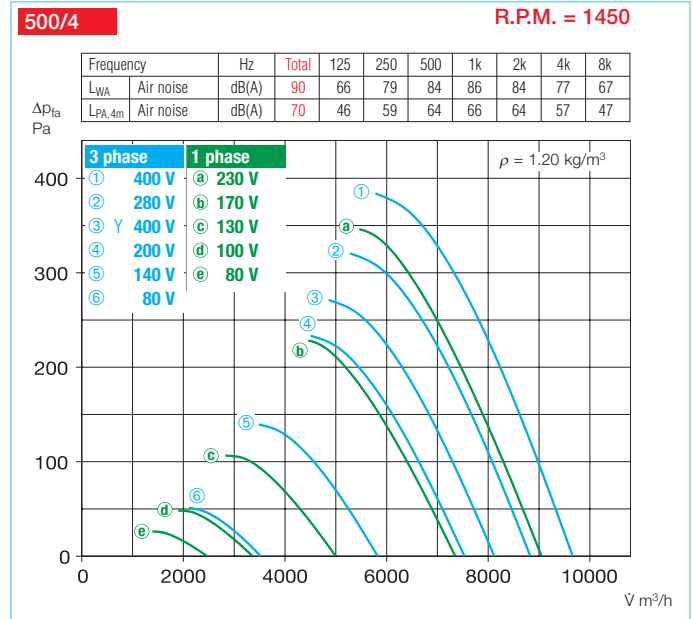
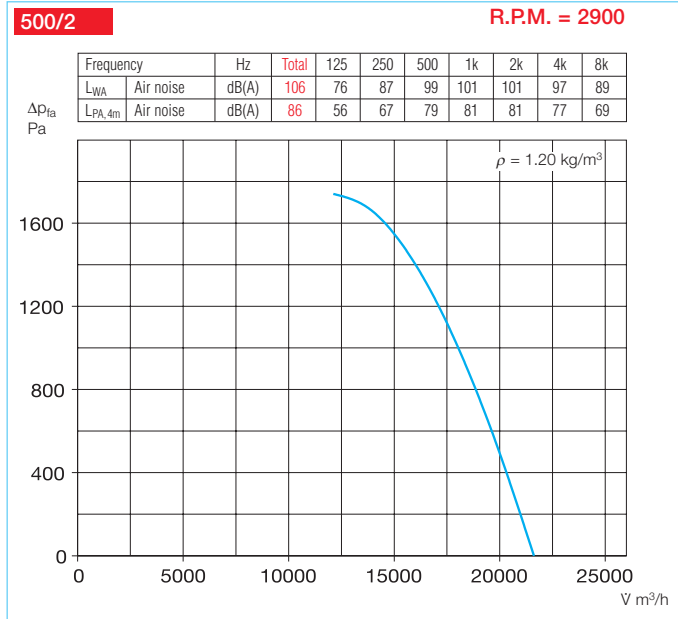

Other accessories	Page
<b>Accessories for ex-proof fans</b>	
Flanged flexible connector Type STS 500 Ex Ref. no. 2507	
Flexible sleeve Type FM 500 Ex Ref. no. 1694	
Attenuators	421 on
Shutters and grilles	487 on
Speed controllers and switches	525 on

Accessories Specification see page 231 on

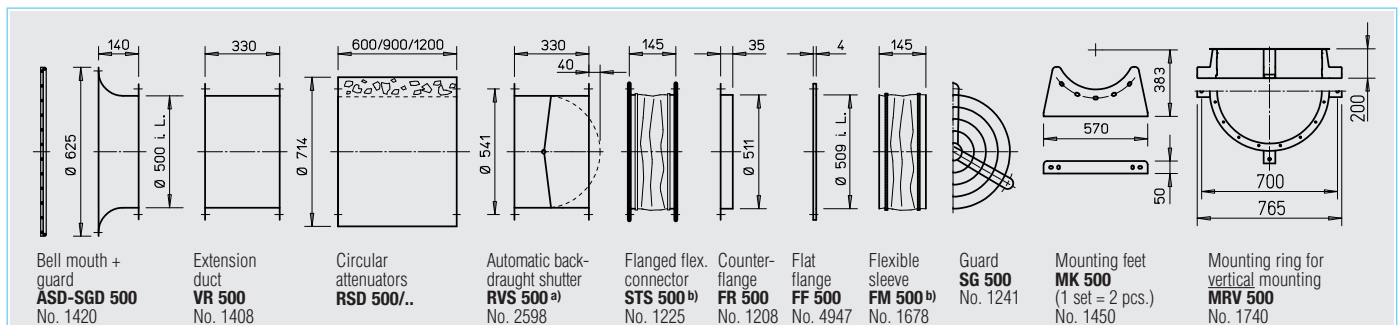

<sup>a)</sup> For motorised shutters see accessory pages

<sup>b)</sup> Types for explosion proof fans see left page

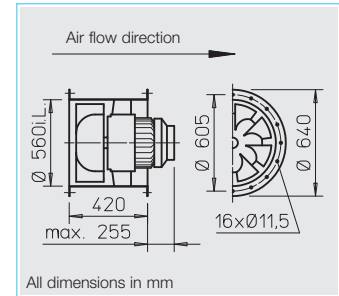

**■ Specification**

**□ Casing**

Manufactured in galvanised sheet steel with flanges on both sides to DIN 24155, Pt. 3, with fixed guide vanes and motor support.

**□ Impeller**

Optimised for high pressure and performance. Specially developed mixed-flow curved impeller manufactured from hot dipped galvanised steel.

**□ Motor**

Direct driven, maintenance free flange motor, totally enclosed with an aluminium casing and cooling fins, protected to IP 54. Sealed for life ball bearings with tropicalized protection of windings and interference-free. Optional drainage holes made to order (please state installation position).

**□ Speed control**

The voltage controllable models are identified by a value in the “speed controlled” column of the table below which must be used when selecting a controller (see controller column). The air flow volumes can be seen from the characteristic curves. Explosion proof fans are not controllable.

**□ Electrical connection**

Terminal box fitted externally on the casing as standard (IP 55).

**□ Installation**

Installation in any position. Ensure that motor drainage holes (where used) face downwards.

**□ Motor protection**

All models (excluding ex-proof models and pole switch models) have thermal contacts and PTC Thermistors as standard which must be connected to a full motor protection unit (see table below) for effective motor protection. Models without thermal contacts must be protected by a conventional circuit breaker.

**□ Sound levels**

Data shown within the performance curves refer to sound power levels. For determination of the lower sound pressure levels refer to diagram on “Technical information” page. Sound emission and acoustic information on page 10 on.

**■ Information Page**

Technical description	208
Selection chart	209
Information for planning	10 on

**Made to order designs**

Alternative voltages, frequencies, protection classes, acid protection, high temperatures etc. are available on request.

For safety and correct use note the technical information on page 15 on.

Type	Ref. no.	R.P.M.	Air flow volume (FID)	Motor power*	Voltage	Current*		Wiring diagram	Maximum air flow temp.		Nominal weight (net)	5 step transformer controller Pole switch		Full motor protection starter using the motor thermal contacts		Anti vibration mounts	
						standard supply	speed controlled		standard supply	speed controlled		Type	Ref. no.	Type	Ref. no.	comp	susp
			min <sup>-1</sup>	∇ m <sup>3</sup> /h	V	A	A	No.	+°C	+°C	kg	Type	Ref. no.	Type	Ref. no.	Type	Type
<b>Two-speed, 3 ph., 50 Hz, Y/Δ switch, protection to IP 54</b>																	
<b>VARD 560/4/4</b>	6711	1130/1380	10780/12810	2.20/3.00	400Y/Δ	3.5/5.9	6.5	520	60	40	95.0	<b>RDS 7<sup>1)</sup></b>	1578	<b>M 4<sup>2)</sup></b>	1571	<b>SDD 2</b>	<b>SDZ 2</b>
												Pole switch					
<b>VARD 560/8/4</b>	6790	705/1440	6590/13570	0.90/3.60	400	2.9/8.3	—	471	60	—	100.0	<b>PDA 12<sup>3)</sup></b>	5081	—	—	<b>SDD 2</b>	<b>SDZ 2</b>
<b>Explosion proof, E Exe II, 3 ph. / 50 Hz, temperature class T1-T3, protected to IP 54</b>																	
<b>VARD 560/8 Ex</b>	6712	700	7120	0.37	400	1.61	—	470	40	—	85.0	not permitted	not permitted	<b>SDD 2</b>	<b>SDZ 2</b>		
<b>VARD 560/6 Ex</b>	6713	900	9360	1.10	400	3.10	—	470	40	—	90.0	not permitted	not permitted	<b>SDD 2</b>	<b>SDZ 2</b>		
<b>VARD 560/4 Ex<sup>4)</sup></b>	6714	1440	14980	3.60	400	7.70	—	498	40	—	105.0	not permitted	not permitted	<b>SDD 2</b>	<b>SDZ 2</b>		

\* Ex models: For nominal value of motor see information on page 16

<sup>1)</sup> includes full motor protection unit

<sup>2)</sup> includes operation and speed switch

<sup>3)</sup> see product page for flush mounted version

<sup>4)</sup> Vibration monitoring is necessary (on site) pursuant to DIN EN 14986.

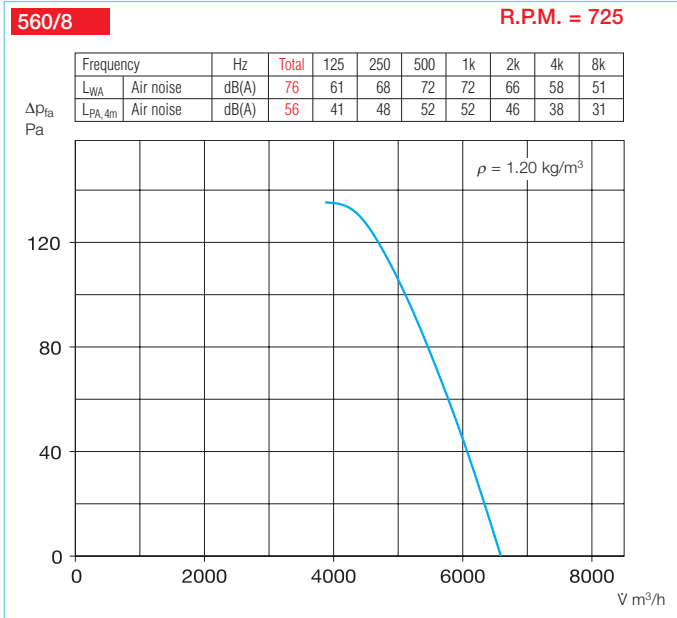
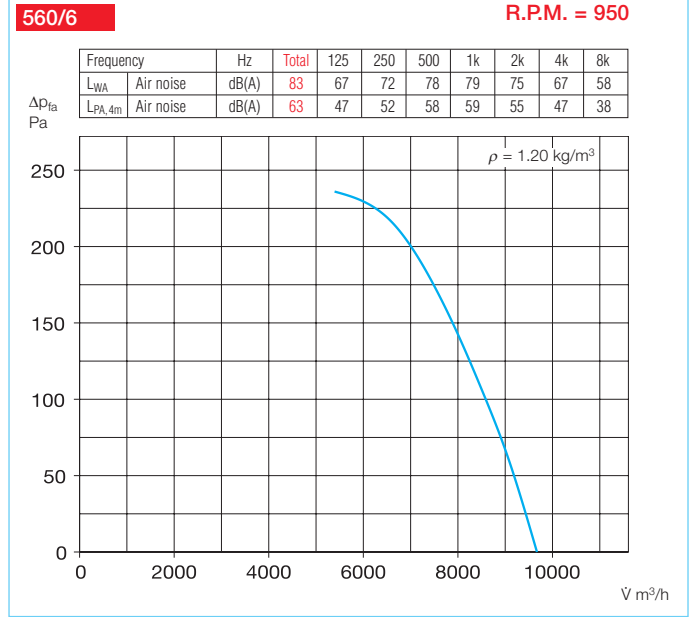
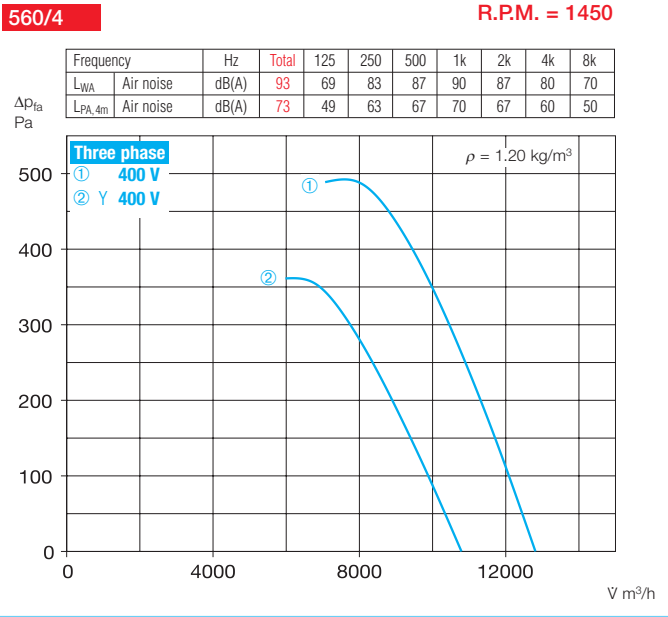

Other accessories	Page
<b>b) Accessories for ex-proof fans</b>	
<b>Flanged flexible connector</b>	
Type STS 560 Ex	Ref. no. 2508
<b>Flexible sleeve</b>	
Type FM 560 Ex	Ref. no. 1695
Attenuators	421 on
Shutters and grilles	487 on
Speed controllers and switches	525 on

**Accessories** Specification see page 231 on

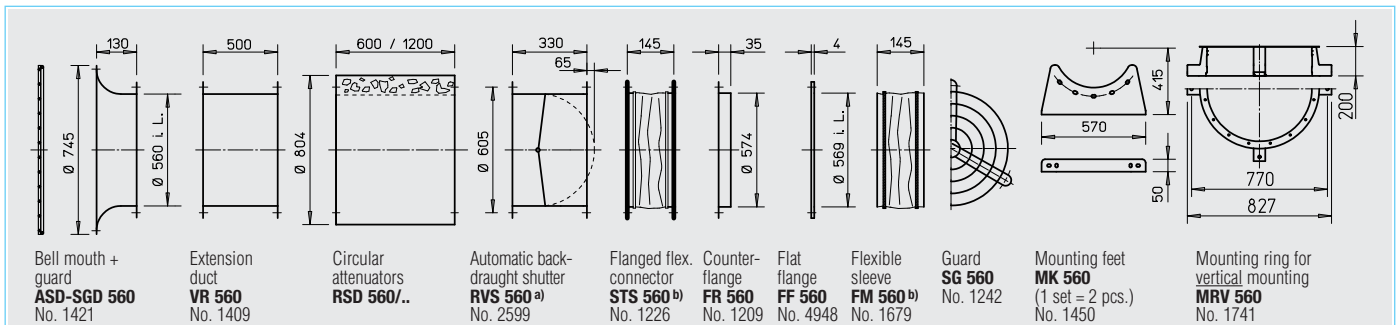

a) For motorised shutters see accessory pages

b) Types for explosion proof fans see left page

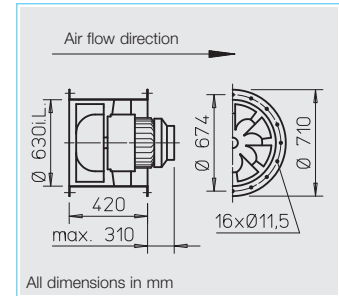

**■ Specification**

**□ Casing**

Manufactured in galvanised sheet steel with flanges on both sides to DIN 24155, Pt. 3, with fixed guide vanes and motor support, hot dipped galvanised.

**□ Impeller**

Optimised for high pressure and performance. Specially developed mixed-flow curved impeller manufactured from hot dipped galvanised steel.

**□ Motor**

Direct driven, maintenance free flange motor, totally enclosed with an aluminium casing and cooling fins, protected to IP 54. Sealed for life ball bearings with tropicalized protection of windings and interference-free. Optional drainage holes made to order (please state installation position).

**□ Speed control**

Stepless (0-100%) by using a frequency inverter (excluding pole switch models). If the fan is to be controlled by a frequency inverter without a sine filter, this must be stated when ordering. This requires a change of fan design and potential additional costs. Explosion proof fans are not controllable.

**□ Electrical connection**

Terminal box fitted externally on the casing as standard (IP 55).

**□ Installation**

Installation in any position. Ensure that motor drainage holes (where used) face downwards.

**□ Motor protection**

Model VARD 630/4 has PTC thermistors which must be connected to a full motor protection unit (see table below) for effective motor protection. Models without thermal contacts must be protected by a conventional circuit breaker.

**□ Sound levels**

Data shown within the performance curves refer to sound power levels. For determination of the lower sound pressure levels refer to diagram on "Technical information" page. Sound emission and acoustic information on page 10 on.

**■ Information Page**

Technical description	208
Selection chart	209
Information for planning	10 on

**Made to order designs**

Alternative voltages, frequencies, protection classes, acid protection, high temperatures etc. are available on request.

For safety and correct use note the technical information on page 15 on.

Type	Ref. no.	R.P.M.	Air flow volume (FID)	Motor power*	Voltage	Current*		Wiring diagram	Maximum air flow temp.		Nominal weight (net)	5 step transformer controller Pole switch		Full motor protection starter using the motor thermal contacts		Anti vibration mounts		
						standard supply	speed controlled		supply	speed controlled		Type	Ref. no.	Type	Ref. no.	comp	susp	
			min <sup>-1</sup>	V m <sup>3</sup> /h	kW	V	A	A	No.	+°C	+°C	kg	Type	Ref. no.	Type	Ref. no.	Type	Type
<b>3 Phase motor, 50 Hz, protection to IP 54</b>																		
VARD 630/4	6717	1440	21320	6,20	400	12,0/6,9	—	776	60	—	145,0	FU-BS 14 <sup>1)</sup>	5463	MSA <sup>4)</sup>	1289	SDD 2	SDZ 2	
													Pole switch					
VARD 630/8/4	6792	715/1430	10590/21170	1,40/5,50	400	5,0/12,0	—	471	60	—	145,0	PDA 12 <sup>3)</sup>	5081	—	—	SDD 2	SDZ 2	
<b>Explosion proof, E Exe II, 3 ph. / 50 Hz, temperature class T1-T3, protection to IP 54</b>																		
VARD 630/8 Ex	6718	700	10220	0,95	400	2,75	—	470	40	—	110,0	not permitted	not permitted	SDD 2	SDZ 2			
VARD 630/6 Ex	6719	950	13990	1,90	400	4,70	—	470	40	—	130,0	not permitted	not permitted	SDD 2	SDZ 2			
VARD 630/4 Ex <sup>5)</sup>	6720	1435	21400	6,80	400	13,1	—	498	40	—	165,0	not permitted	not permitted	SDD 2	SDZ 3			

\* Ex models: For nominal value of motor see information on page 16  
<sup>3)</sup> see product page for flush mounted version

<sup>1)</sup> includes full motor protection unit and Sine filter  
<sup>4)</sup> for PTC Thermistor temp. sensor

<sup>2)</sup> includes operation and speed switch  
<sup>5)</sup> Vibration monitoring is necessary (on site) pursuant to DIN EN 14986.

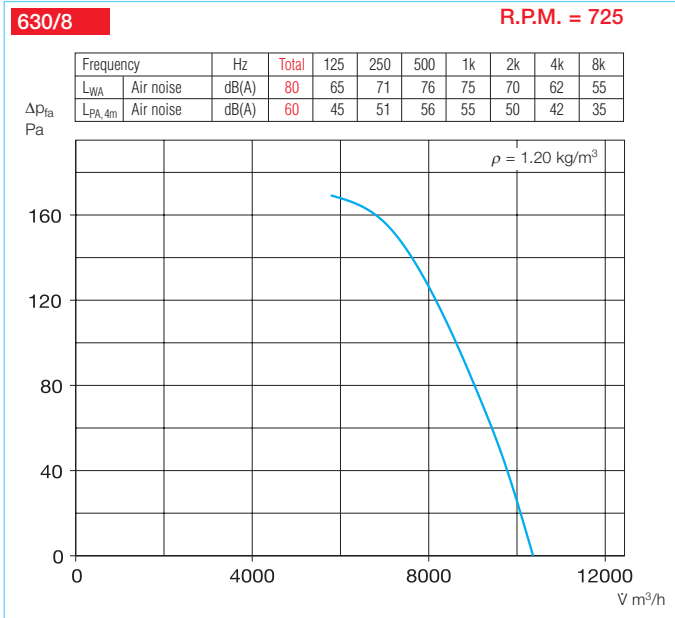
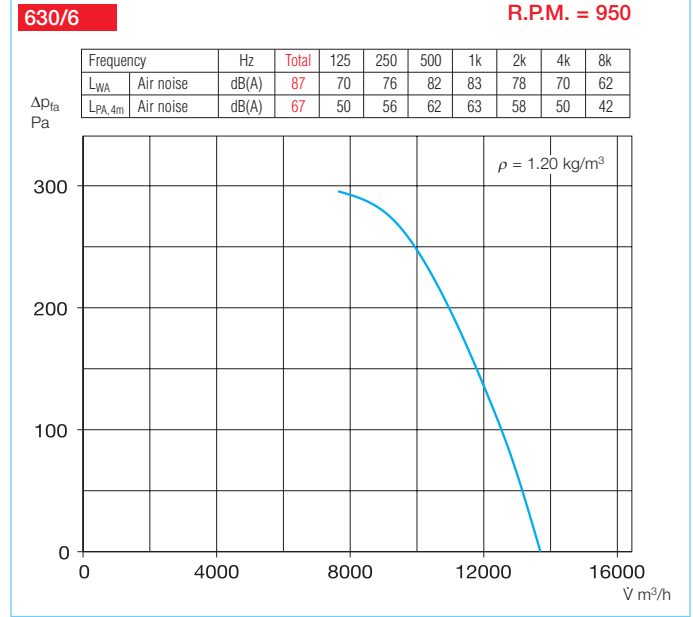
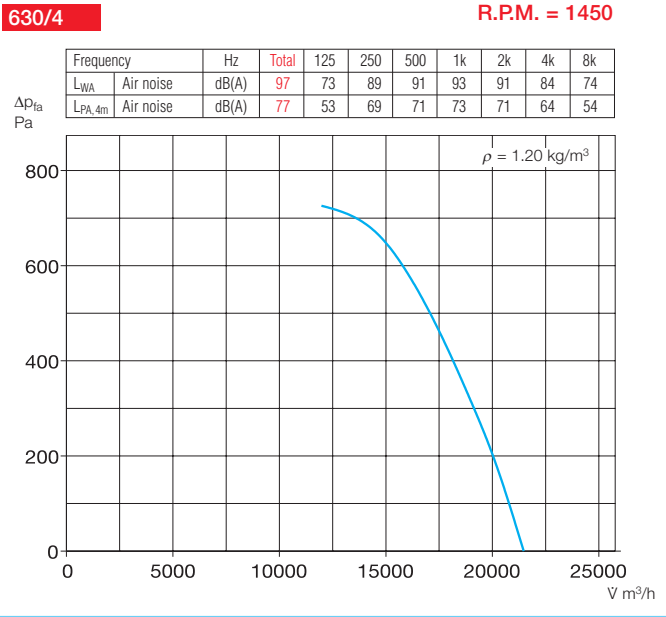

Other accessories	Page
<b>b) Accessories for ex-proof fans</b>	
<b>Flanged flexible connector</b>	
Type STS 630 Ex	Ref. no. 2509
<b>Flexible sleeve</b>	
Type FM 630 Ex	Ref. no. 1696
Attenuators	421 on
Shutters and grilles	487 on
Speed controllers and switches	525 on

**Accessories** Specification see page 231 on

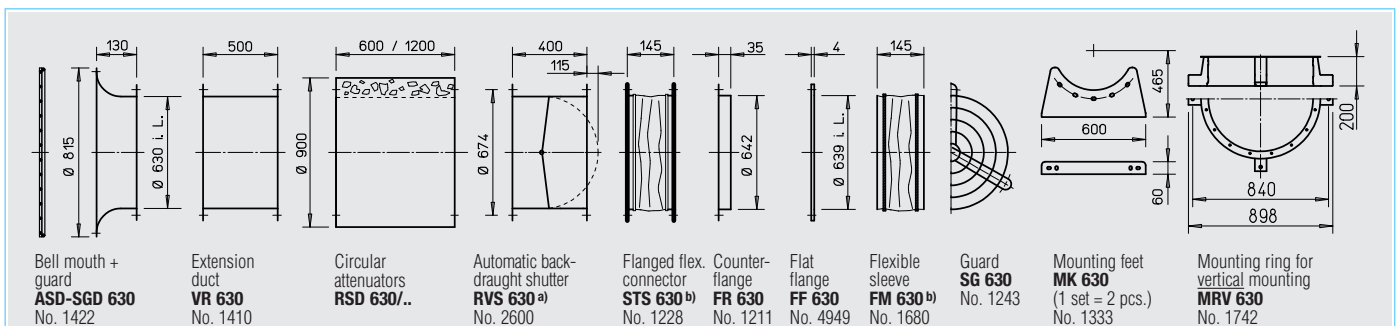

a) For motorised shutters see accessory pages

b) Types for explosion proof fans see left page